

## Introduction

To harvest Sweetwater from the effects of Limestone, The optimization of juice purification is the most important step in getting and maintaining a balanced juice that in turn can be made into products used around the world. Sugar beet deterioration, alkalinity, carbon content, and external temperatures all play a massive role in the final product, which is putting it into our cakes and granola bars. With the processes of heating, cooling, evaporation, and adding external chemical/biological ingredients, the chemical structure of beet sugar juice can vary drastically. If not done correctly, the chemicals and products used in the purification can have negative long-lasting impacts on our local and statewide environments.

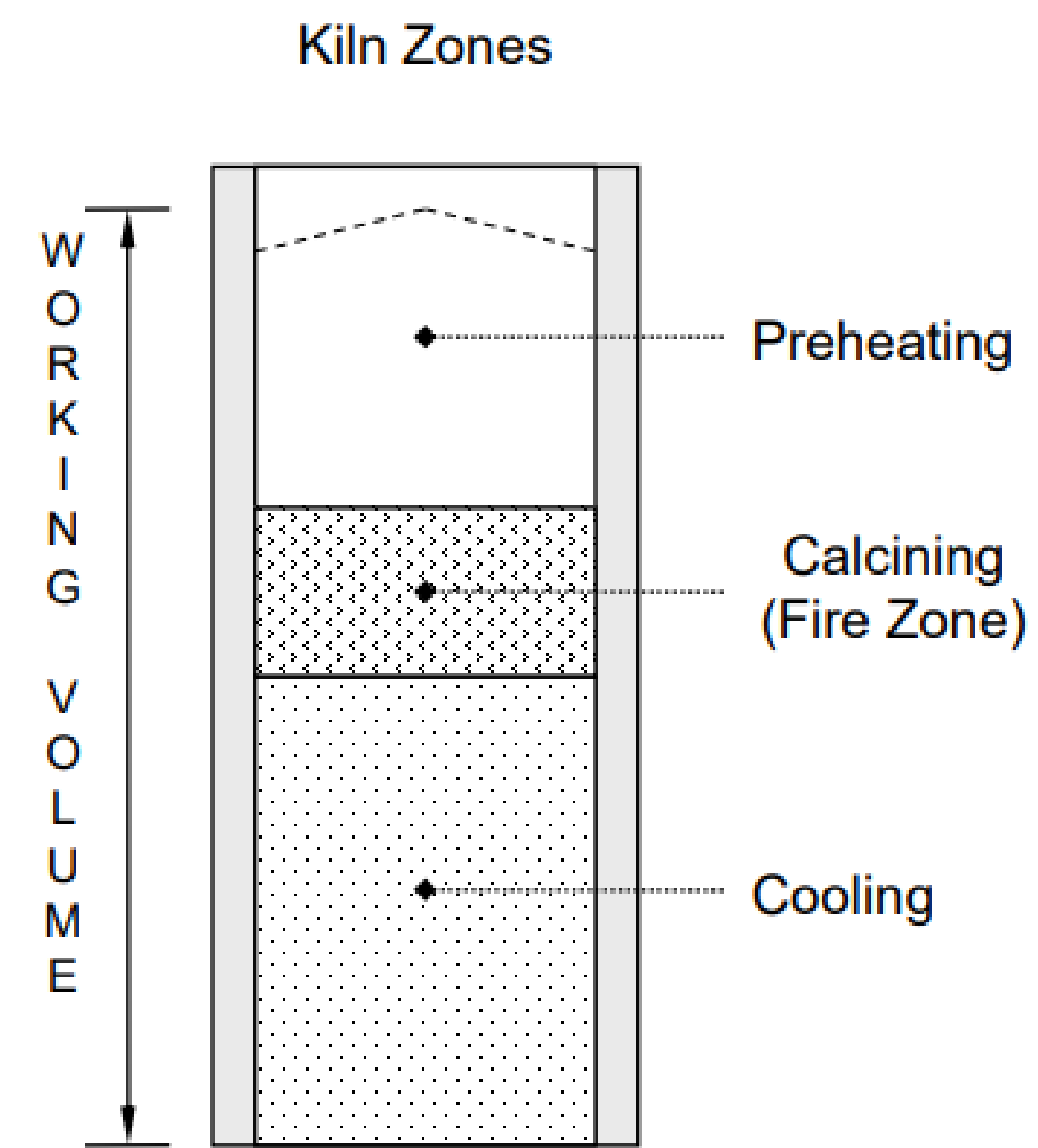

Figure 1. lime kiln zones

## Sensitive Units

The process of sugar production has many factors that affect the total yield of the product. The subsystem that has the greatest impact on the total yield is the lime-kiln.

The lime-kiln consists of three zones: preheat, fire zone, and cooling<sup>3</sup>:

- The preheat zone consists of a heat exchanger, hot gases, and coke<sup>3</sup>. This zone helps to remove volatiles from the subsystem<sup>3</sup>.
- The fire zone is where coke/coal combusts, CO<sub>2</sub> gas is removed, and calcining/burning occurs<sup>3</sup>.
- The kiln is the cooling zone which has the counter-current heat exchanger, hot rocks, and the incoming air<sup>3</sup>.

Looking at the subsystem, there are three inputs: Coke, Limestone, and Combustion Air<sup>2</sup>. The properties that are monitored are flow rates, temperature, time, beet condition, and pH. Increasing the amount of limestone causes the sweet water to be more acidic<sup>2</sup>. The optimal pH falls between 11.0 – 11.4 pH which causes the maximum sugar to be extracted from the beets within the system<sup>2</sup>.

## Research

### Hypothesis:

- If Limestone processing is optimized to be more efficient, then a more consistent Sweetwater pH will be reached.

### Objective:

- Optimize Limestone processing in a way that isn't harmful to the surrounding environment.
- Gain a more consistent pH in Sweetwater.

### Task:

- Researching various sensors, heating methods, and alternative fuel sources to maximize the pH leveling efficiency of limestone and Coke.

### Process:

- Research for optimization would start with finding a kiln heating method that maintains a more consistent temperature and rock size, followed by finding a cleaner renewable resource to heat the kilns themselves. Lastly, sensors would be implemented to carefully monitor changes and correlations to Sweetwater pH.

## Process Description

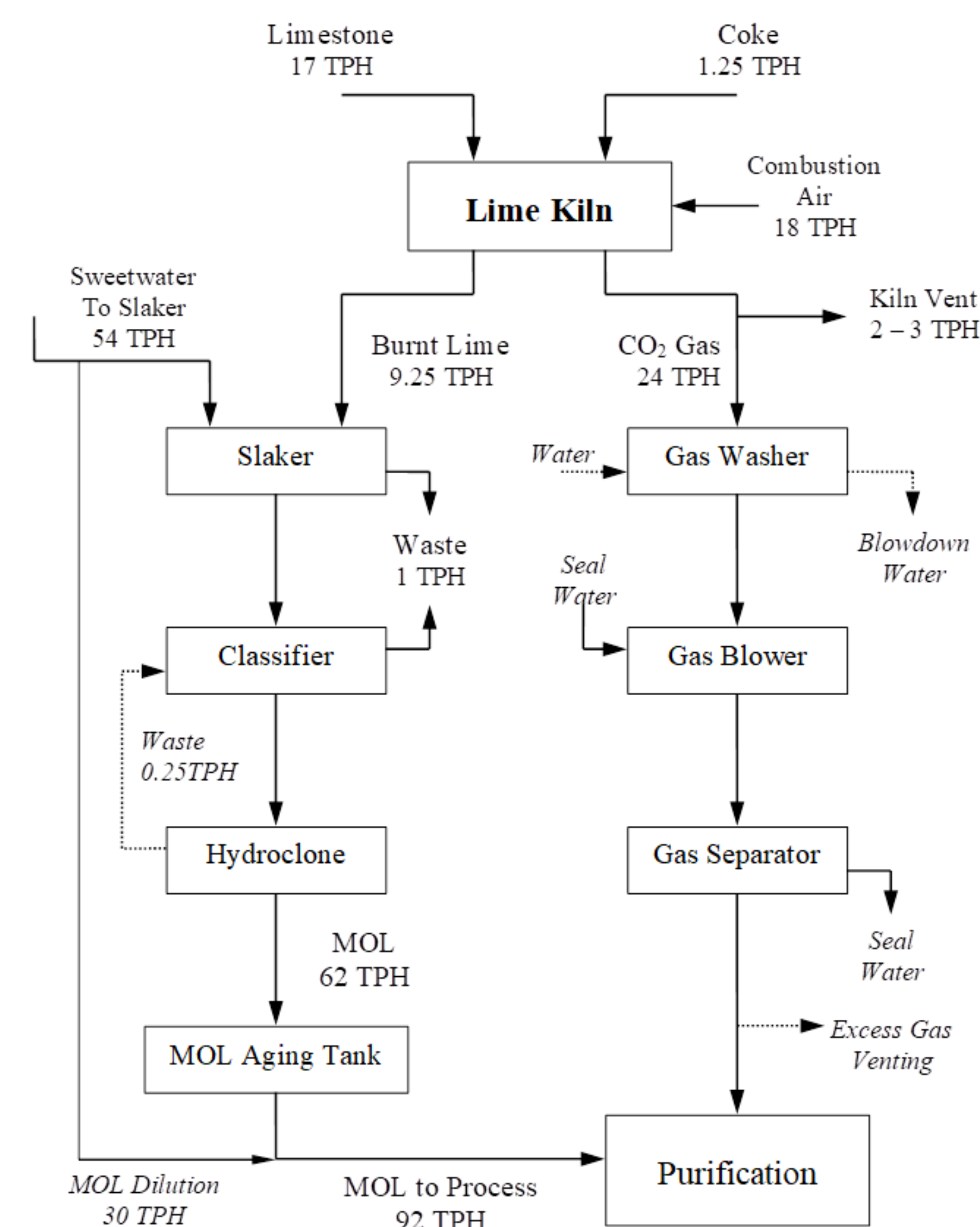

Figure 2. Process flowchart for limestone to juice purification.

The flowchart shown in **Figure 2** depicts the process that Limestone undergoes to effectively purify the beet-sugar juice. Coke, which is a form of highly carbonated fuel for the limekiln, is added in conjunction with limestone to begin the breakdown of limestone into a form that can rapidly purify the juice. Air is added to provide oxygen for the combustion reactions, and Sweetwater (sugar juice) is added to the slaker drums to begin the purification process. Sweetwater is constantly recycled throughout the system to ensure that there is enough contact between limestone and Sweetwater. The right-hand side of the process depicts the addition of CO<sub>2</sub> gas, which helps separate impurities from the Sweetwater which in turn effect the pH.

## Impact On Ecosystem Services



Figure 3. Wastewater pond where excess Sweetwater and limestone slurry runoff goes to.

The pulp waste from the sugar beets can have positive effect on the ecosystem as it can be used as an efficient organic fertilizer. The use of the excess beet pulp has shown to have little-to-no effect on the pH of the soil and adds more nitrogen and phosphorus in the soil<sup>1</sup>

The runoff from the wastewater, consisting of plant material, Sweetwater, and limestone slurry, can have harmful effects on the surrounding environment that has a mixed effect on the surrounding environment. The limestone slurry from the wastewater can regulate the pH of nearby aquatic ecosystems through the hardness it adds, but the combination of effluents in the wastewater decompose and then can absorb all the oxygen in an ecosystem and harm the organism population, especially the fish population.

## References

1. Bezler, N. V., & Holopkin, I. N. (2017). Potential of beet pulp as organic fertilizer. *Sakharnaya Svekla*, (8), 23-30.
2. Kraus, W.; Stark T.; Rad M. A.; Mauch W. (1997): Investigations of conditions for optimum colloid coagulation in preliming of beet juice. *Zuckerind.* 122 (1197) Nr. 2, S. 91-99
3. *Lime Kiln Design and operation - beet sugar development ...* (n.d.). Retrieved April 20, 2022, from <https://bsdf-assbt.org/wp-content/uploads/2018/01/ASSBTVol8IIP190to196Lime20Kiln20Design20and20Operation.pdf>
4. Schwarzkopf, Florian. *Lime Burning Technology : A Manual for Line Plant Operators*. Kennedy Van Saun Corp., 1974.
5. SMITH-PETER, SUSAN. "SWEET DEVELOPMENT: The Sugar Beet Industry, Agricultural Societies and Agrarian Transformations in the Russian Empire 1818-1913." *Cahiers Du Monde Russe*, vol. 57, no. 1, 2016, pp. 101-24, <https://www.jstor.org/stable/26369062>. Accessed 19 Apr. 2022.
6. 9.10.1.2 *Sugarbeet Processing - US EPA*. EPA. (n.d.). Retrieved April 20, 2022, from <https://www3.epa.gov/ttnchie1/ap42/ch09/final/c9s10-1b.pdf>
7. "Sugarcane." WWF, World Wildlife Fund, <https://www.worldwildlife.org/industries/sugarcane#:~:text=Sugar%20mills%20produce%20wastewater%2C%20emissions,leading%20to%20massive%20fish%20kills.>