

2017 Michigan Energy Code-Commercial

Michigan Energy Code Training and Implementation Program

3.0 Hour Commercial Program Course Number **CP-17-00112**



USE LESS.
**SAVE
MORE.**

Consumers Energy

Count on Us®

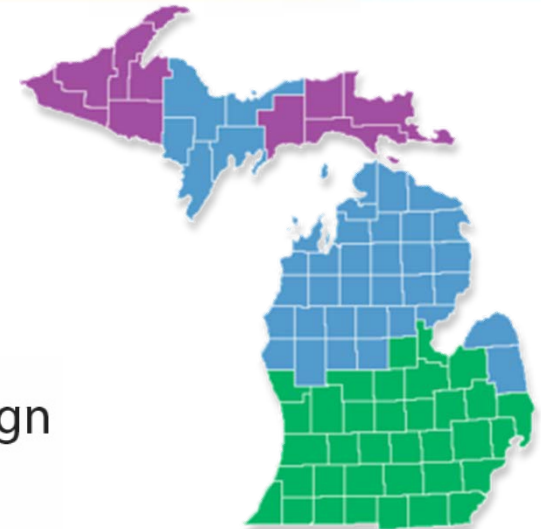

NAVIGANT

MICHIGAN STATE

UNIVERSITY

School of Planning, Design
and Construction

Presenters

Michigan Commercial Energy Code Training and Implementation Program:

Course Number:

CP-17-00112

3 Hours Technical:

All Categories

BI, BO, PR, MI, EI, PI

Pending

Tim Mrozowski, A.I.A. LEED®

AP

Instructor # 1455

Marcus Metoyer

Instructor # 1540

William Bezdek, P.E.

Instructor # 1616

Project Support

Prepared by:

The School of Planning, Design and Construction
At Michigan State University

Project funding provided by:

DTE Energy and Consumers Energy

Technical support provided by:

Navigant

Michigan Energy Code-Commercial

- Michigan updated its Commercial Energy Code and it is effective September 20, 2017
- The Code is now referred to as the “Michigan Energy Code”



Overall Training Project Objectives

To train *building officials, inspectors, architects, engineers, contractors, subcontractors, suppliers, and owners* in the revised Michigan energy code for the purpose of:

1. Increasing understanding
2. Improving compliance
3. Reducing administrative time
4. Improving customer relationships

Program Learning Objectives

- Understand the structure of Michigan's 2017 Commercial Energy Code based on portions of IECC 2015 and ASHRAE 90.1 (2013)
- Understand the scoping and administrative requirements of Michigan's 2017 Commercial Energy Code
- Identify significant prescriptive and mandatory technical changes for building envelope, HVAC, Service Water Heating, Power and Lighting in Michigan's new Commercial Energy Code which apply to Michigan commercial building and LEED projects
- Describe alternate compliance paths including COMCheck, the Energy Cost Budget Method, Whole Building Simulations and Appendix G for LEED projects

Presentation Overview

- Background on new code
- Michigan code status
- When does it apply?
- Significant changes
- Code requirements
- Other Compliance Paths
 - Energy cost budget method
 - COMCheck
 - Whole Building Simulations – Appendix G and LEED V4 Requirements



Disclaimer

This presentation presents an educational overview of the significant changes in the Michigan Energy Code for Commercial Buildings effective September 20, 2017.

While it is believed to be accurate it is not intended to substitute for actual code language. Code language is addressed only generally and is not verbatim, language is paraphrased and not all code sections are addressed in this presentation. Designers, contractors, code officials etc, should always use the actual code in projects.

National Commercial Energy Code Status

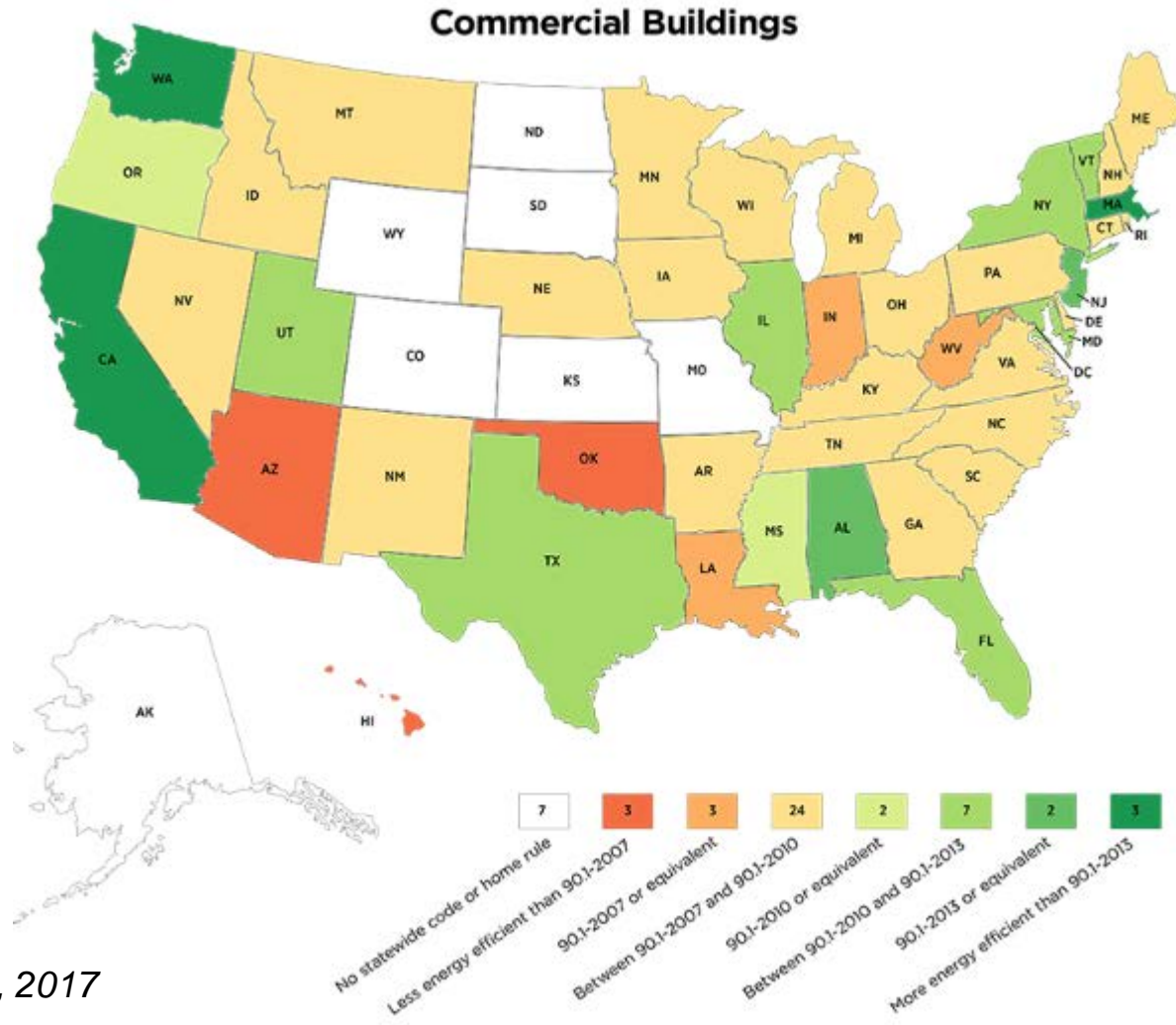

As July 31, 2017

Viewed September 5, 2017 <https://www.energycodes.gov/status-state-energy-code-adoption>

Why Energy Codes?

Energy Use in United States

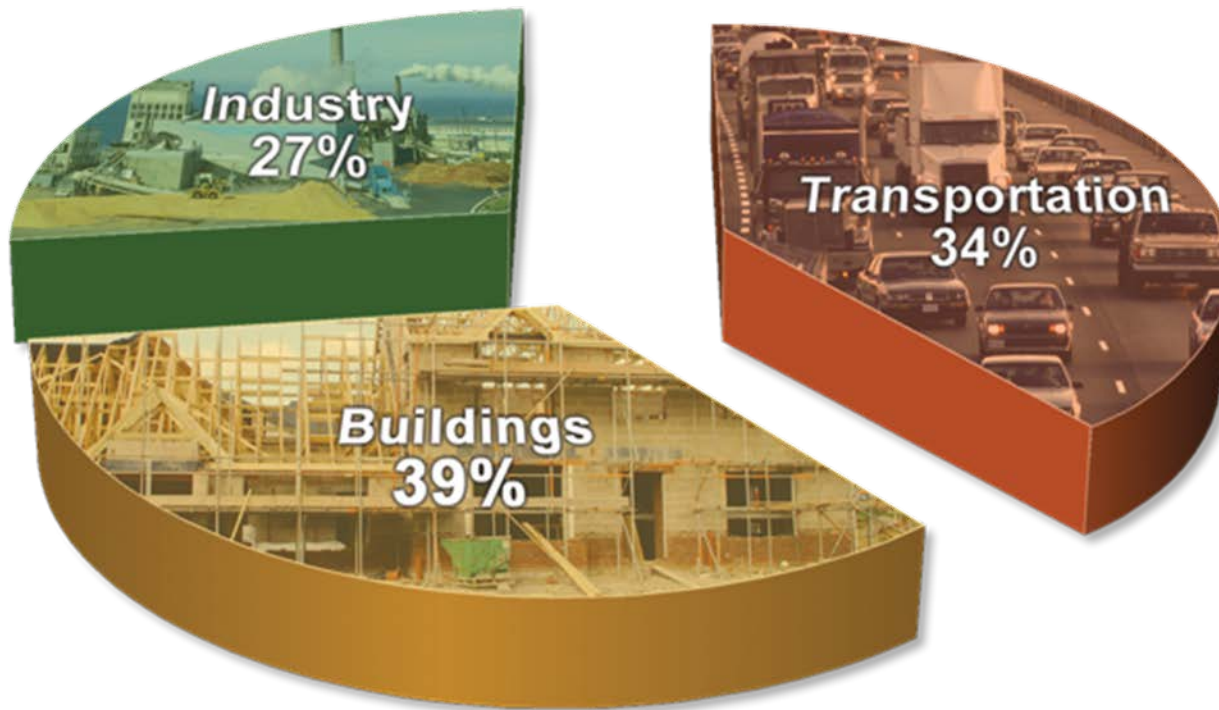

Source US DOE

Impact of Energy Codes

Improvement in ASHRAE Standard 90.1 (Year 1975-2013)
(Commercial Buildings)

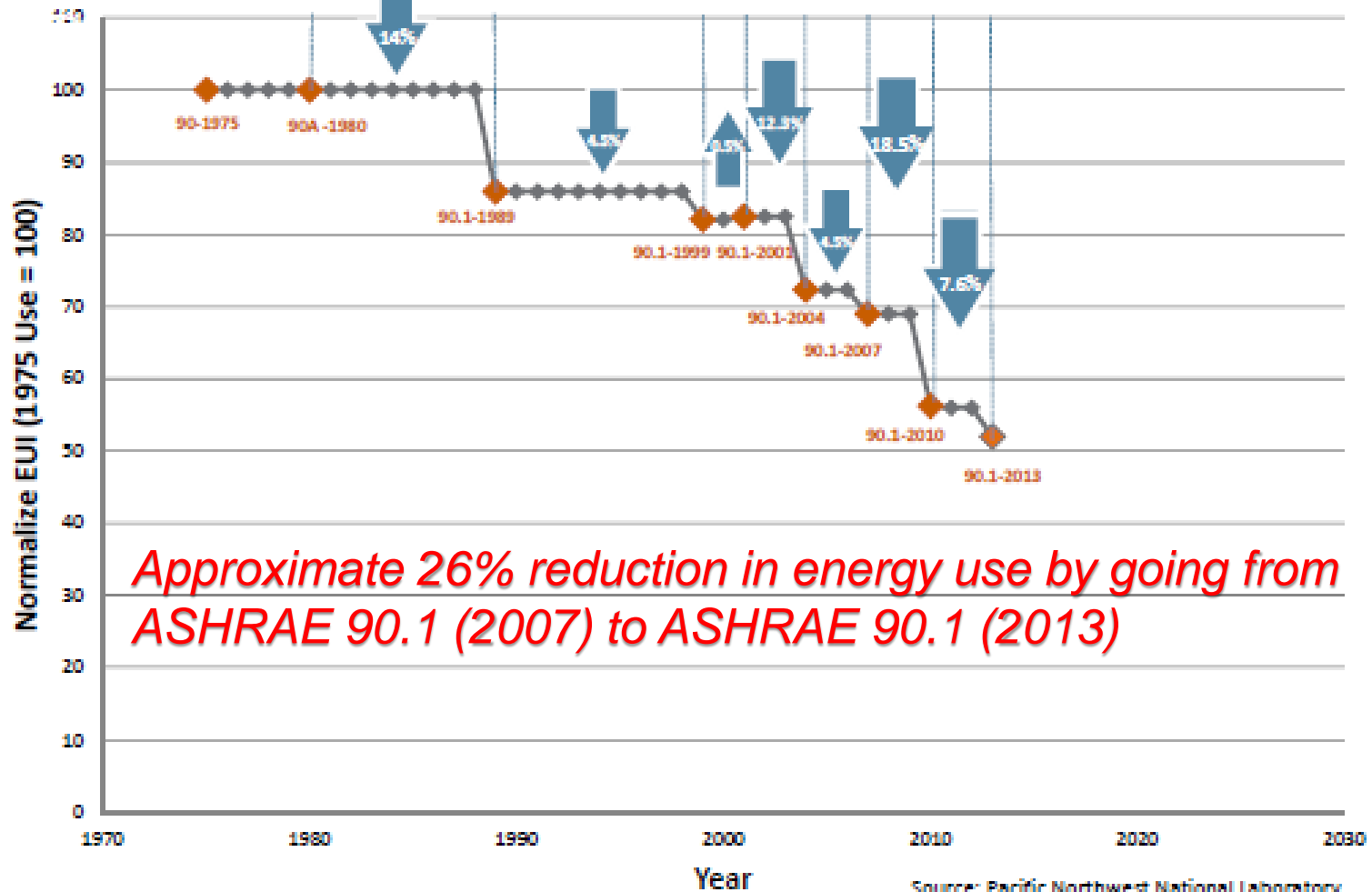

What do energy codes cover?

- **Building Envelope**
- **Mechanical**
- **Service Water Heating**
- **Lighting**
- **Electrical Power**

U.S. DOE: Code Official's Resource Guide (2010)

Role and Structure

General Requirements:

- Mandatory provisions
- Required information
- Labeling requirements

- Requirements to install per manufacturer requirements

Michigan Residential Energy Code (1 of 2)

- Michigan adopted IECC (2015) with Michigan Amendments
- Entitled “Michigan Energy Code”
- Effective Feb 2016
- Merged provisions of IECC (2015) Chapters 1 (Scope and Application), 2 (Definitions), 3 (General Requirements) and 4 (Residential Energy Efficiency) into a single Chapter 11 in the Michigan Residential Code MRC (2015)

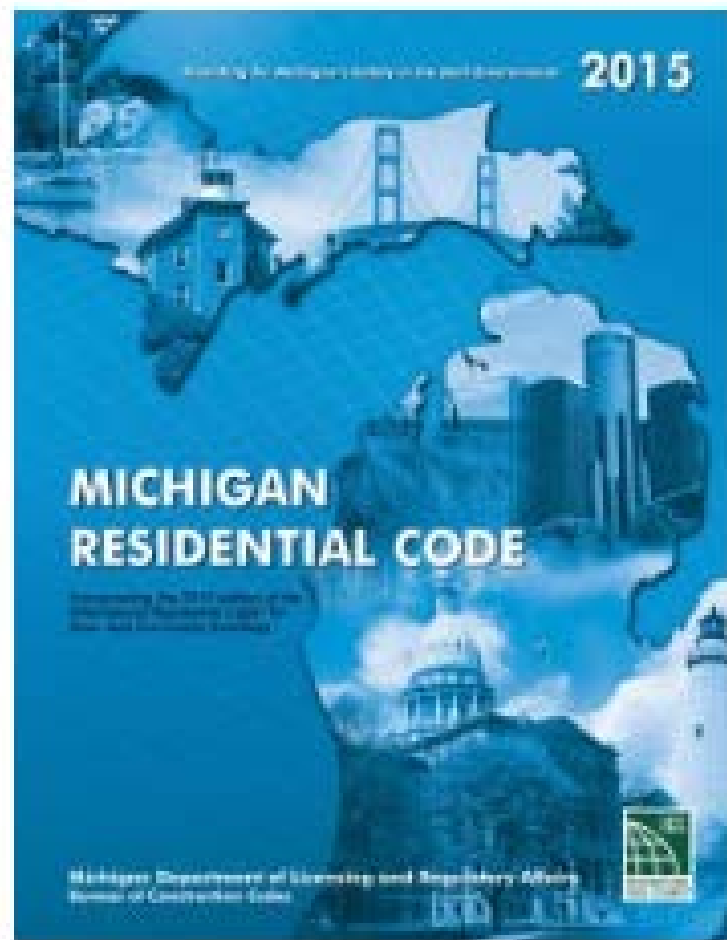

Michigan Residential Energy Code (2 of 2)

MRC Chapter 11 Applies to:

- Applies to one and two family dwellings and townhouses
- Will be applied to buildings classified as R2, R3, R4 not more than three stories above grade

Note. R1 (Hotels, Motels, Boarding Houses, Congregate Housing more than 10 people) are under Michigan Commercial energy code

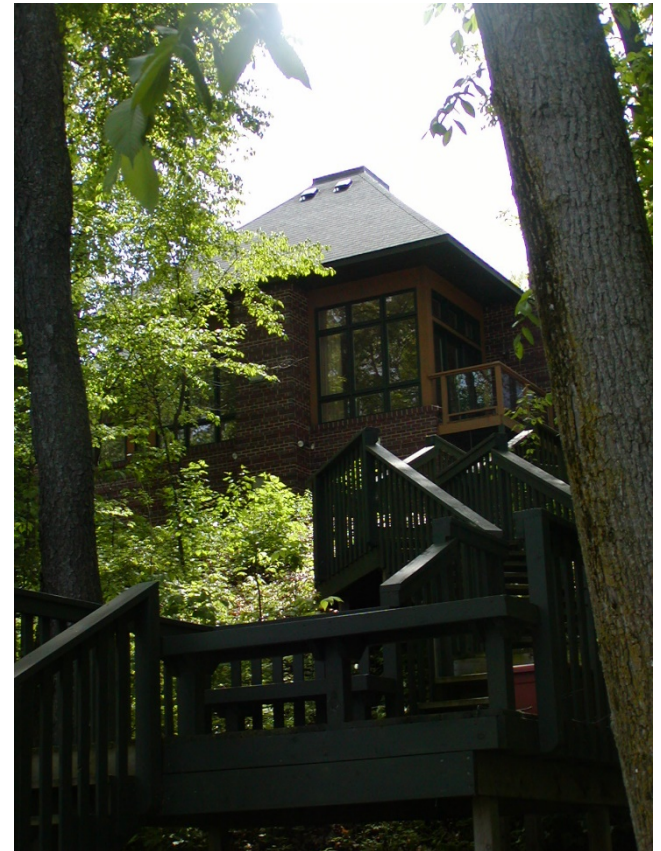

Mixed Construction Types - Residential

One story steel + 3-4 stories wood residential over first floor retail with fire separation

Governed under the Michigan commercial energy code



Michigan Energy Code Commercial (1 of 9)

Three documents are needed in addition to various reference standards

- The modifying Act Language from the Department of Licensing and Regulatory Affairs dated August 1, 2016
- The International Energy Conservation Code 2015 (IECC 2015)
- The ASHRAE 90.1 (2013) (ASHRAE 90.1 (2013) (referred to as the “Standard”))

Michigan Energy Code Commercial (2 of 9)

Michigan Commercial Energy Code = the Act + portions of IECC 2015 + ASHRAE 90.1 (2013)

DEPARTMENT OF ENERGY, LABOR, AND ECONOMIC GROWTH LICENSING
AND REGULATORY AFFAIRS

DIRECTOR'S OFFICE

CONSTRUCTION CODE

Filed with the Secretary of State
These rules take effect 120 days after filed with the Secretary of State

(By authority conferred on the director of the department of ~~energy, labor, and economic growth licensing~~ and regulatory affairs by section 4 of 1972 PA 230, MCL 125.1504, and Executive Reorganization Order Nos. 2003-1, ~~and~~ 2008-430, and 2011-4, MCL 445.2011, ~~and~~ MCL 445.2025, and MCL 445.2030)

R. 408.31087, R. 408.31087a, R. 408.31088, and R. 408.31090 of the Michigan Administrative Code are amended and R. 408.31089 is rescinded and R. 408.31087b, R. 408.31088a, R. 408.31091, R. 408.31092, R. 408.31092a, R. 408.31093, R. 408.31094, R. 408.31095, R. 408.31096, R. 408.31097, R. 408.31098, R. 408.31098a, and R. 408.31098b are added to the code as follows:

PART 10a MICHIGAN UNIFORM ENERGY CODE

R. 408.31087. Applicable code.

Rule 1087. Rules governing the energy efficiency for the design and construction of buildings and structures, not including residential buildings, shall be those contained in the international energy conservation code, 2009/2015 edition, section 501.1, except for sections C107.2 to C107.5, C108.2 to C108.4, C301.2, C301.3, C302, C401.2.1 to C408.3.2, C502.2 to C502.2.6.2, C503.2 to C503.6 and the ASHRAE energy standard for buildings except low-rise residential buildings, ANSI/ASHRAE/IESNA standard 90.1-2008/2013 (hereafter the standard), including appendices A, B, C, and D, and G, except for sections 8.4.2, 8.4.3 to 8.4.3.2. With the amendments noted, Section 501.1, of the international energy conservation code and the standard are adopted in these rules by reference. The Michigan uniform energy code is available for inspection or purchase at the ~~Construction~~ office of the Michigan Department of ~~Energy, Labor and Economic Growth Licensing~~ and Regulatory Affairs, Bureau of Construction Codes, 2501 Woodlake Circle, Okemos, Michigan 48864-6111 W. Ottawa Street, Lansing, Michigan 48933. The code may be purchased from the International Code Council, through the bureau's website at www.michigan.gov/bcc, at a cost as of the time of adoption of these rules of \$38.00/\$44.00 or may be purchased from the International Code Council, 500 New Jersey

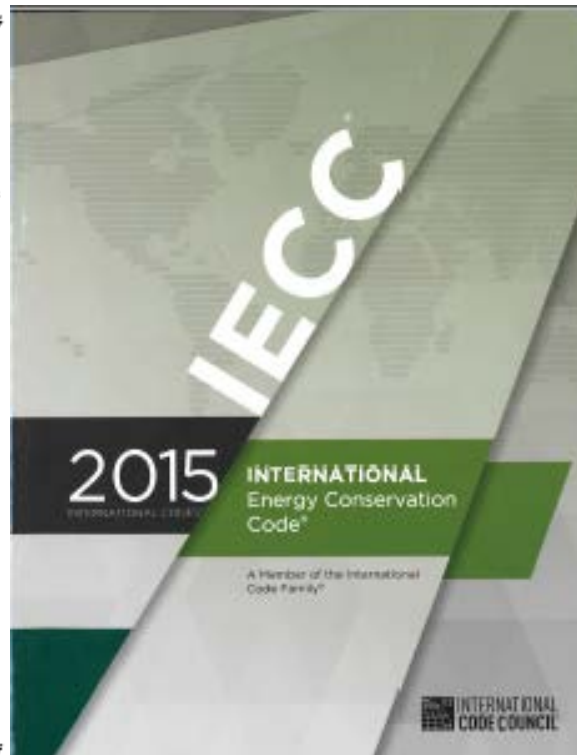

STANDARD

ANSI/ASHRAE/IES Standard 90.1-2013
(Supersedes ANSI/ASHRAE/IES Standard 90.1-2010)
Includes ANSI/ASHRAE/IES Addenda listed in Appendix F

Energy Standard for Buildings Except Low-Rise Residential Buildings (I-P Edition)

See Appendix F for approval dates by the ASHRAE Standards Committee, the ASHRAE Board of Directors, the IES Board of Directors, and the American National Standards Institute.

This standard is under continuous maintenance by a Standing Standard Project Committee (SSPC) for which the Standards Committee has established a documented program for regular publication of addenda or revisions, including procedures for timely, documented, consensus action on requests for change to any part of the standard. The change submittal form, instructions, and deadlines may be obtained in electronic form from the ASHRAE website (www.ashrae.org) or in paper form from the Manager of Standards. The latest edition of an ASHRAE Standard may be purchased from the ASHRAE Web site (www.ashrae.org) or from ASHRAE Customer Service, 1791 Tullie Circle, NE, Atlanta, GA 30329-2305. E-mail: orders@ashrae.org. Fax: 678-539-2129. Telephone: 404-636-8400 (worldwide), or toll free 1-800-527-4723 (for orders in US and Canada). For reprint permission, go to www.ashrae.org/permissions.

© 2013 ASHRAE

ISSN 1041-2336



Michigan Energy Code Commercial (3 of 9)

Act defines adoptions, ammendments and deletions

DEPARTMENT OF ENERGY, LABOR, AND ECONOMIC GROWTH LICENSING
AND REGULATORY AFFAIRS

DIRECTOR'S OFFICE

CONSTRUCTION CODE

Filed with the Secretary of State

These rules take effect 120 days after filed with the Secretary of State

(By authority conferred on the director of the department of energy, labor, and economic growth licensing and regulatory affairs by section 4 of 1972 PA 230, MCL 125.1504, and Executive Reorganization Order Nos. 2003-1, and 2008-420, and 2011-4, MCL 445.2011, and MCL 445.2025, and MCL 445.2030)

R.408.31087, R.408.31087a, R.408.31088, and R.408.31090 of the Michigan Administrative Code are amended and R.408.31089 is rescinded and R.408.31087b, R.408.31088a, R.408.31091, R.408.31092, R.408.31092a, R.408.31093, R.408.31094, R.408.31095, R.408.31096, R.408.31097, R.408.31098, R.408.31098a, and R.408.31098b are added to the code as follows:

PART 10a
MICHIGAN UNIFORM ENERGY CODE

R.408.31087. Applicable code.

Rule 1087. Rules governing the energy efficiency for the design and construction of buildings and structures, not including residential buildings, shall be those contained in the international energy conservation code, 2009/2015 edition, section 501.1, except for sections C107.2 to C107.5, C108.2 to C108.4, C301.2, C301.3, C302, C401.2.1 to C408.3.2, C502.2 to C502.2.6.2, C503.2 to C503.6 and the ASHRAE energy standard for buildings except low-rise residential buildings, ANSI/ASHRAE/IESNA standard 90.1-2009/2013 (hereafter the standard), including appendices A, B, C, and D, and G, except for sections 8.4.2, 8.4.3 to 8.4.3.2. With the amendments noted, Section 501.1, of the international energy conservation code and the standard are adopted in these rules by reference. The Michigan uniform energy code is available for inspection or purchase at the ~~Construction~~ Licensing office of the Michigan Department of Energy, Labor and Economic Growth Licensing and Regulatory Affairs, Bureau of Construction Codes, 1501 Woodlake Circle, Okemos, Michigan 48864611 W. Ottawa Street, Lansing, Michigan 48933. The code may be purchased from the International Code Council, through the bureau's website at www.michigan.gov/bcc, at a cost as of the time of adoption of these rules of \$38.00/\$44.00 or may be purchased from the International Code Council, 500 New Jersey

Michigan Energy Code Commercial (4 of 9)

Scoping requirements in referenced sections of IECC 2015

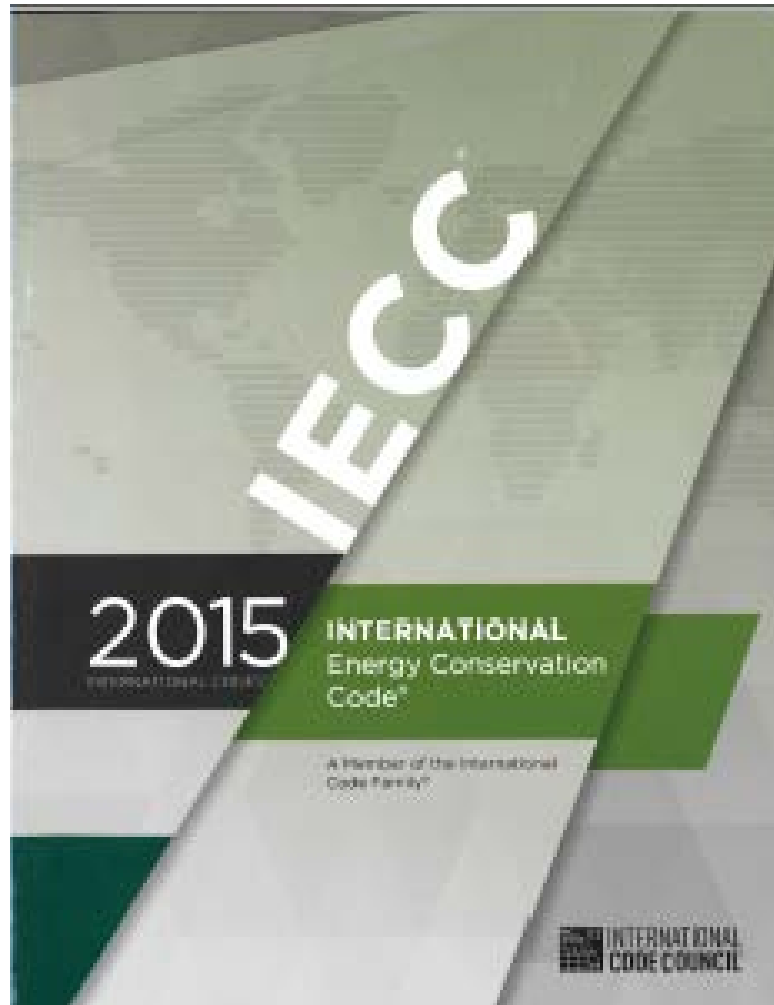

Michigan Energy Code Commercial (5 of 9)

Technical provisions In ASHRAE 90.1 (2013)

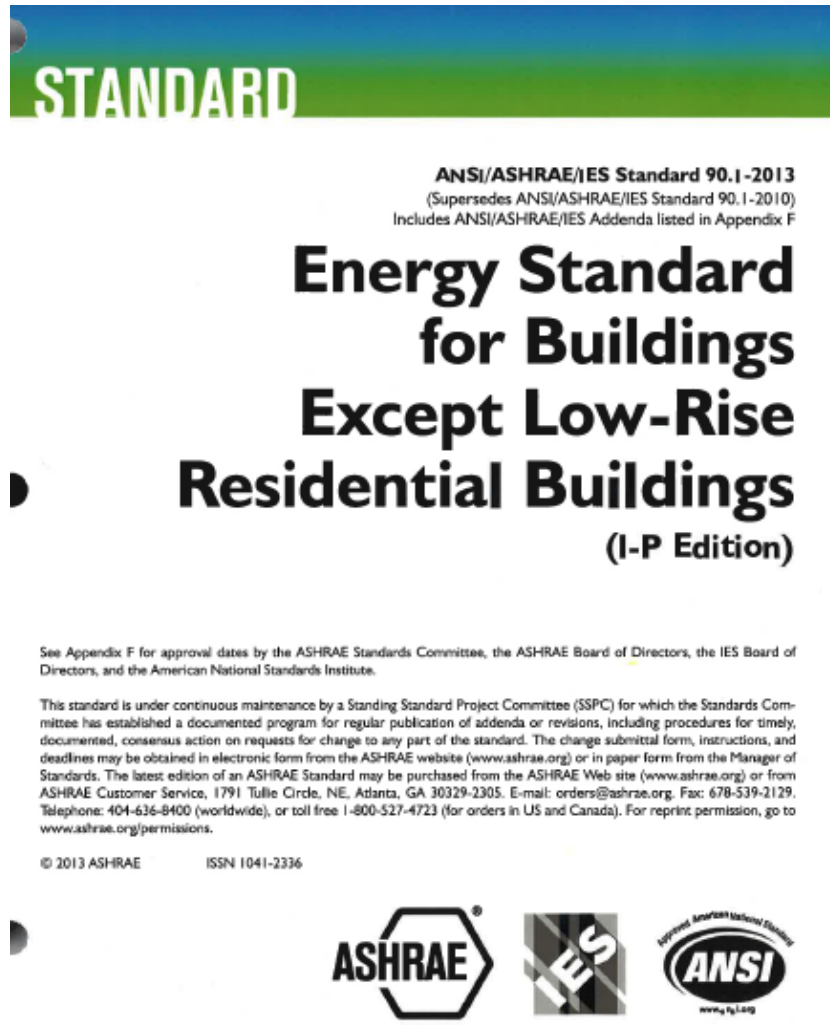

Michigan Energy Code Commercial (6 of 9)

The Act either directly or indirectly lays out:

- The portions of IECC 2015 and ASHRAE 90.1 which are used or not used and any deletions and changes
 - Direct= explicit statement that something is included or not included
 - Indirect = when you must navigate to a section and view any amendments or deletions to learn if something is included or excluded.

Act Language

The international energy conservation code, ~~2009~~**2015** edition, ~~section 501.1,~~ ***except for sections C107.2 to C107.5, C108.2 to C108.4, C301.2, C301.3, C302, C401.2.1 to C408.3.2, C502.2 to C502.2.6.2, C503.2 to C503.6***

and the ASHRAE energy standard for buildings except low-rise residential buildings, ANSI/ASHRAE/IESNA standard 90.1-~~2007~~**2013** (hereafter the standard), including appendices A, B, C, ~~and D,~~ **and G, *except for sections 8.4.2, 8.4.3 to 8.4.3.2***. With the amendments noted, ~~Section 501.1,~~ of the international energy conservation code and the standard are adopted in these rules by reference.

Michigan Energy Code Commercial (7 of 9)

Navigating the changes:

- Map and mark in your books the applicable sections, deletions, amendments and changes referenced in the Act language to sections in:
 - IECC 2015
 - ASHRAE 90.1 (2013)

Michigan Energy Code Commercial (8 of 9)

IECC 2015 Layout:

Commercial Provisions-prefaced by “C”

Residential Provisions prefaced by “R” (Not applicable to this training)

Michigan Energy Code Commercial (9 of 9)

IECC 2015 Commercial “C” Chapters:

1. Chapter 1 Scope and Administration (portions Used in Michigan Energy Code)
2. Chapter 2 Definitions (used in Michigan Energy Code)
3. Chapter 3 General Requirements
4. Chapter 4 Commercial Energy Efficiency
5. Chapter 5 Existing Buildings
6. Chapter 6 Reference Standards
7. Index

Chapter 1 Scope and Administration (1 of 7)

IECC 2015 Changes indicated by Michigan Act
Language **(MARK YOUR BOOKS)**

CHAPTER 1 (CE) SCOPE AND ADMINISTRATION

Michigan deletes or amends sections as follows:

PART 1- 101 SCOPE AND GENERAL REQUIREMENTS

SECTION C101

C101.1 Title (amended by Mich. Act to refer to the code as the “Michigan Energy Code”)

Chapter 1 Scope and Administration (2 of 7)

SECTION C102

C102.1.1 *(amended by Mich. Act to identify example above code programs such as ICC 700 (2012) Silver and Energy Star Version 3 as complying,*

***Still requires mandatory provisions of Chapter 4 of IECC 2015 to be met*

(Note: while Michigan code states Energy Star v3.0, the newer v3.1 may be more appropriate as Energy Star may not recognize v3.0 in states that have adopted IECC 2012 or 2015)

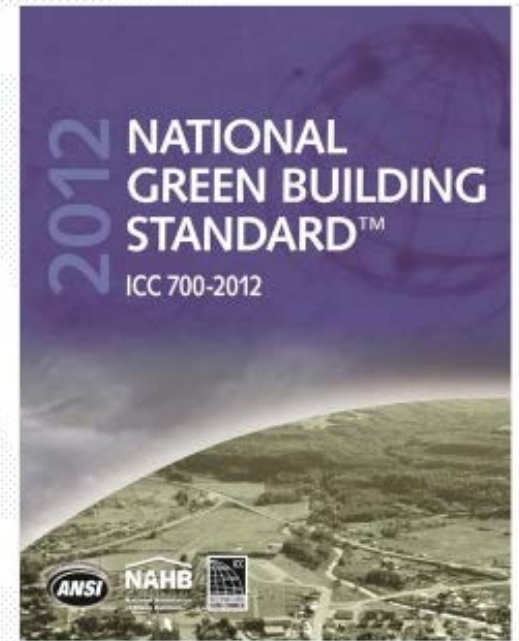

Chapter 1 Scope and Administration (3 of 7)

SECTION C103 CONSTRUCTION DOCUMENTS

amended by Mich. Act to:

- *Require submittal of one or more sets of construction documents, special inspections, structural programs and data etc.*
- *Prepared by or under the direct supervision of a registered design professional when required by the Occupational Code*
- *Also allows for additional documents when required by the building official for special conditions*

Chapter 1 Scope and Administration (4 of 7)

SECTION C104 INSPECTIONS

C104.8 (section added by Mich. Act to address administrative requirements relating to permits, enforcement, interpretations and appeals referenced in the Stille-DeRossett-Hale Single State Construction Code Act (SDHSSCCA))

Chapter 1 Scope and Administration (5 of 7)

SECTION C107 FEES

C107.1 Fees *(not adopted in Mich. Act and then amended in Mich. Act)*

C107.2 Schedule of permit fees *(not adopted by Mich. Act)*

C107.3 Work commencing before permit issuance *(not adopted by Mich. Act)*

C107.4 Related fees *(not adopted by Mich. Act)*

C017.5 Refunds *(not adopted by Mich. Act)*

Chapter 1 Scope and Administration (6 of 7)

SECTION 108 STOP WORK ORDERS

C108.1 *Authority (amended by Mich. Act to be consistent with SDHSSCCA and allows for penalty provisions under SDHSSCCA to be imposed)*

C108.2 *Issuance (not adopted by Mich. Act)*

C108.3 *Emergencies (not adopted by Mich. Act)*

C108.4 *Failure to comply (not adopted by Mich. Act)*

Chapter 1 Scope and Administration (7 of 7)

SECTION 109 BOARD OF APPEALS

C109.1 Means of an appeal (*amended by Mich. Act to address who can appeal*)

Construction Code Commission is the body that hears appeals to a local board of appeals decision.

C109.3 Limitations of Authority
(*amendment is indicated in the Mich. Act but not described*)

Chapter 2 Definitions

CHAPTER (CE) 2 DEFINITIONS

C202 Definitions *(all definitions are included-Michigan amended definitions of building and building official modified to be consistent with SDHSSCCA)*

Note: “Building Official” is not in IECC 2015 (so intent is likely that it would added)

Chapter 3 General Requirements

CHAPTER 3 (CE) GENERAL REQUIREMENTS

C301.1 CLIMATE ZONES

Table C301.1 *(replaces table 301.1 with one indicating climate zones by Michigan counties only)*

Table C301.3.(2) *replaces climate zone definitions for Zones 5A, 6A and 7)*

Figure C301.1 *(added by Mich. Act and shows a map with Michigan counties and climate zones)*

C301.2 Warm humid counties *(not adopted by Mich. Act)*

C301.3 International climate zones *(not adopted by Mich. Act)*

Chapter 3 General Requirements

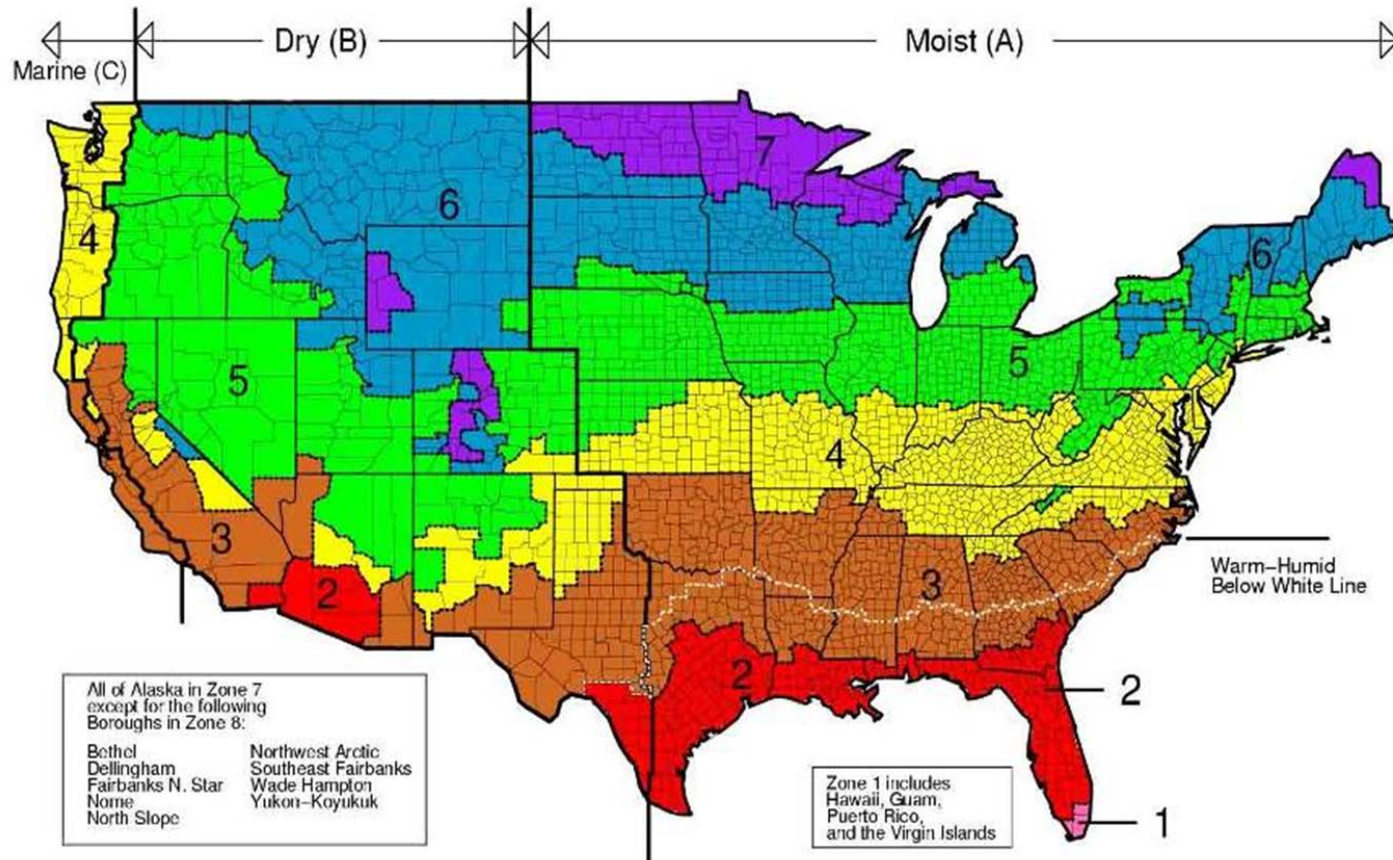

Source US DOE

Chapter 3 General Requirements

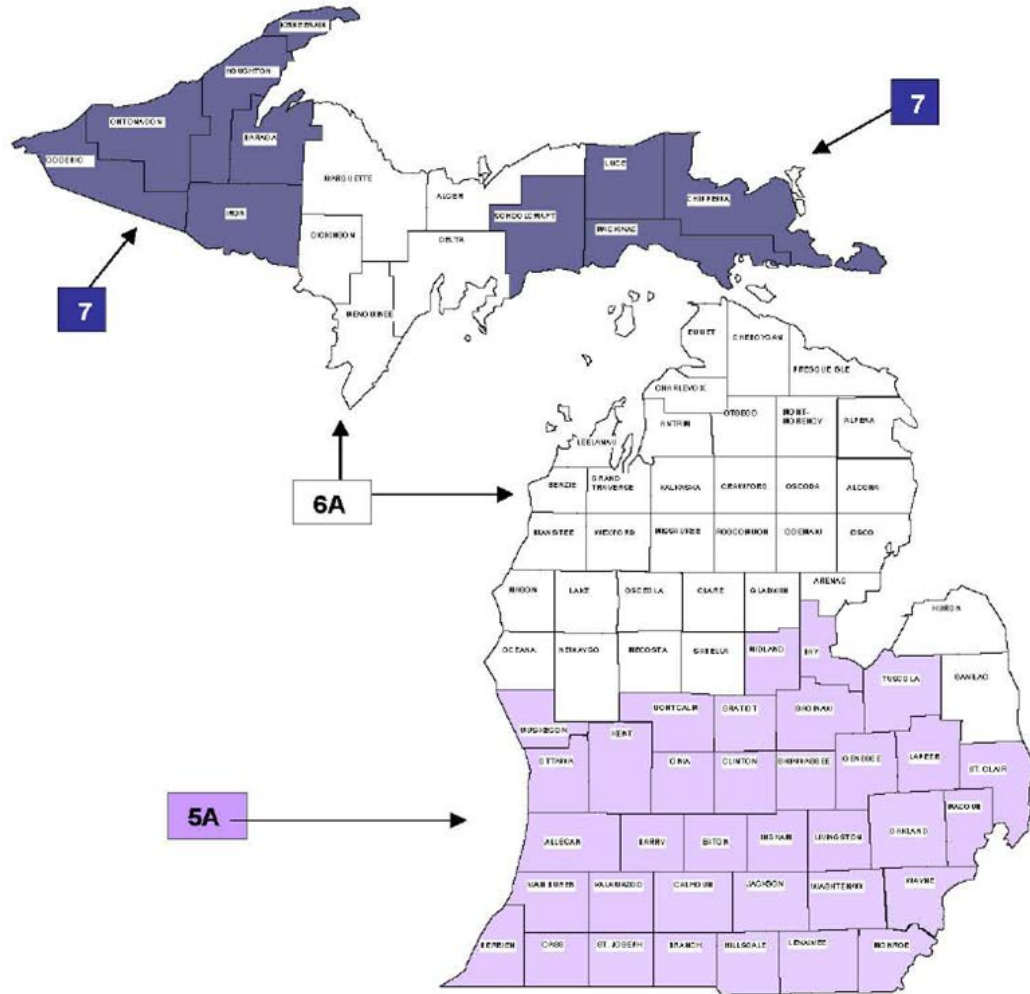

Michigan Uniform Energy Code

Chapter 3 General Requirements (1 of 2)

CHAPTER 3 (CE) GENERAL REQUIREMENTS

C302 Design conditions *(not adopted by Mich. Act)*
(concerns expressed by MI Code Revision
Committee over design temperature limits for facilities
for the elderly, certain medical needs and certain
equipment).

Chapter 3 General Requirements (2 of 2)

CHAPTER 3 (CE) GENERAL REQUIREMENTS:

C303.1.3 Fenestration Product Rating-*(amended by Mich. Act to allow for computer simulations to be used to determine product U factors and indicates conditions when default U factor, SGHC and VT should be used.)*

Fenestration product rating. U-factors or fenestration products (windows, doors, and skylights) shall be determined in accordance with NFRC 100 by an accredited, independent laboratory, and labeled and certified by the manufacturer. Products lacking a labeled U-factor shall be assigned a default U-factor from Table C303.1.3(1) or C303.1.3(2).

Exception:

- 1. Computer simulations by independent NFRC certified laboratories or approval under the Stille-Derossett-Hale Single State Construction Code Act, 1972 PA 230, MCL 125.1501 to 125.1531, is considered in compliance with this section.*
- 2. Where required, garage door U-factors shall be determined in accordance with either NFRC 100 or ANSI/DASMA 105. U-factors shall be determined by an accredited, independent laboratory, and labeled and certified by the manufacturer. Products lacking a labeled U-factor shall be assigned a default U-factor from Table C303.1.3(1) or C303.1.3(2). The solar heat gain coefficient (SHGC) and visible transmittance (VT) of glazed fenestration products (windows, glazed doors, and skylights) shall be determined in accordance with NFRC 200 by an accredited, independent laboratory, and labeled and certified by the manufacturer. Products lacking such a labeled SHGC or VT shall be assigned a default SHGC or VT from table C303.1.3(3).*

Chapter 4 Commercial Energy Efficiency

CHAPTER 4 (CE) COMMERCIAL ENERGY EFFICIENCY

C401.2 APPLICATION *(deleted and replaced by Mich. Act to indicate ASHRAE 90.1 (2013) is used for compliance.)*

C401.2.1-C408.32 *(not adopted by Mich. Act-this deletes the technical provisions of IECC)*

Chapter 5 Existing Buildings (1 of 4)

CHAPTER 5 (CE) EXISTING BUILDINGS

SECTION 5.1.3 (MAY BE TYPO- SHOULD READ

503.1 *(Important amendment by Mich. Act addressing alterations that need not comply with ASHRAE 90.1 (2013) it identifies the following conditions.*

Exceptions:

1. Installation of storm windows or glazing panels over existing glazing, provided the storm window or glazing panel contains a low-emissivity coating. However, a low-emissivity coating is not required where the existing glazing already has a low-emissivity coating. Installation may be either on the inside or outside of the existing glazing.
2. Replacement of glazing in existing sash and frame, provided the U-factor and SHGC will be equal to or lower than before the glass replacement.

Chapter 5 Existing Buildings (2 of 4)

Exceptions (Continued)

3. Alterations to roof or ceiling, wall, or floor cavities that are insulated to full depth with insulation having a minimum nominal value of R-3.0/in.

4. Alterations to walls and floors, where the existing structure is without framing cavities and no new framing cavities are created.

See next slide for exceptions 5-7

8. Replacement of existing fenestration, provided that the area of the replacement fenestration does not exceed 25% of the total fenestration area of an existing building and that the U-factor and SHGC, will be equal to or lower than before the fenestration replacement.

Chapter 5 Existing Buildings (3 of 4)

Exceptions (Continued)

5. Roof recovering.
6. Removal and replacement of a roof membrane where there is existing roof insulation integral to or below the roof deck.
7. Removal and replacement of a roof membrane where the insulation is installed entirely above the roof deck, a minimum of R-20 insulation shall be permitted where the placement of additional insulation greater than R-20 insulation would require either of the following:
 - a. Raising the height of parapets, weep systems, or through wall flashings where roof abuts adjoining walls or parapets.
 - b. Raising the height of mechanical or electrical equipment, mechanical curbs, roof hatches, skylight curbs, service equipment, piping, conduit, duct work, roof platforms, ladders, stairs, guard rails, expansion joints, roof davits, or door thresholds.

Don's Roof



Don's roof - replacement likely exempt if existing R 20. Otherwise would need to comply

Chapter 5 Existing Buildings (4 of 4)

C503.2-Change space conditioning *(not adopted by Mich. Act)*

C502.2-502.2.6.2 *(not adopted by Mich. Act)*

C503.2-Change space conditioning *(not adopted by Mich. Act)*

C503.3-Building Envelope *(not adopted by Mich. Act)*

C503.4 Heating and cooling systems *(not adopted by Mich. Act)*

C503.5-Service hot water systems *(not adopted by Mich. Act)*

C503.6 Lighting Systems *(not adopted by Mich. Act)*

***These sections were not adopted because ASHRAE 90.1 (2013) was adopted to cover the technical provisions**

ASHRAE 90.1 (2013) MICHIGAN AMENDMENTS (1 of 5)

Technical provisions In ASHRAE 90.1 (2013)

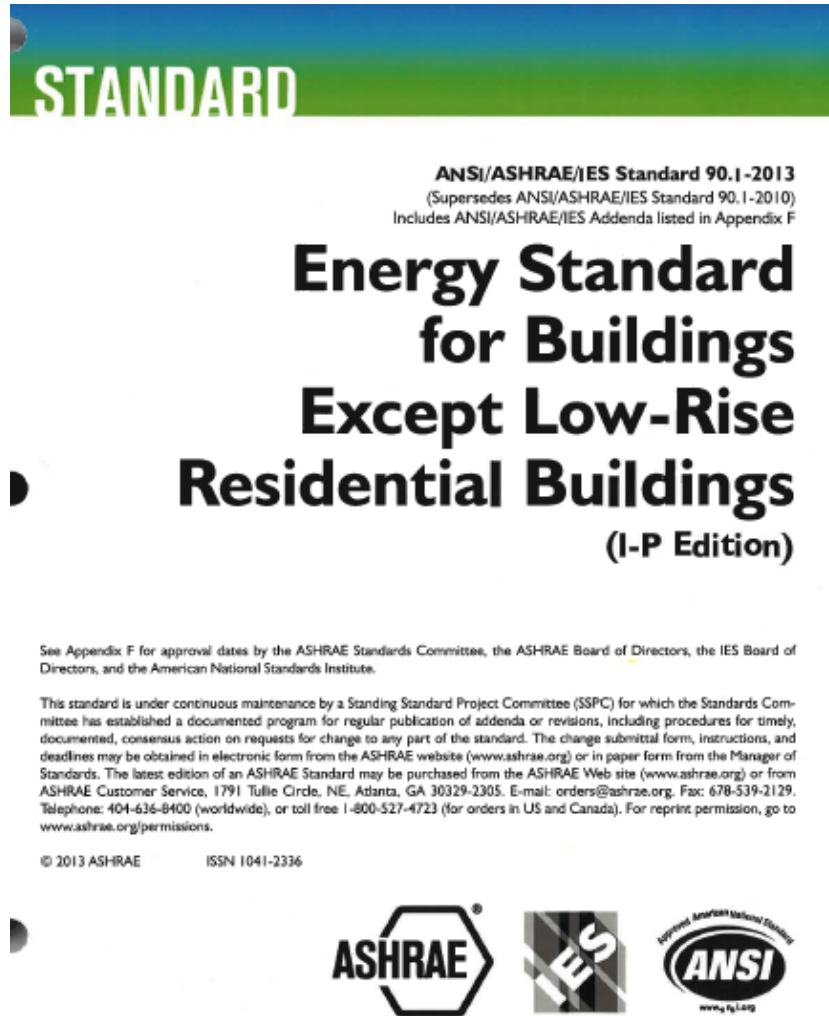

ASHRAE 90.1 (2013) MICHIGAN AMENDMENTS (2 of 5)

ASHRAE 90.1 (2013) MICHIGAN AMENDMENTS (MARK YOUR BOOKS) *Three Items are amended by Michigan*

Key word is “Standard” in the Michigan Act.

- **Section 5.4.3.4 Vestibules (Mich. Act amends exceptions for when a vestibule is not required)**
- **Section 6.7.2.4 System Commissioning (Mich. Act amends system commissioning for HVAC controls for projects over 10,000 SF rather than the SF 50,000 indicated in ASHRAE 90.1 (2013)).**
- **Section 9.1.2 Lighting Alterations (Mich. Act amends the exception for when lighting needs to comply with the code during alterations to 50% of connected load rather than the 10% indicated in ASHRAE 90.1 (2013)).**

ASHRAE 90.1 (2013) MICHIGAN AMENDMENTS (3 of 5)

Section 5.4.3.4 Vestibules *(Mich. Act amends exceptions for when a vestibule is not required)*

Rule 1098a. Section 5.4.3.4 of the standard is amended to read as follows:

5.4.3.4. Vestibules. Building entrances that separate conditioned space from the exterior shall be protected with an enclosed vestibule, with all doors opening into and out of the vestibule equipped with self-closing devices. *Vestibules shall be designed so that in passing through the vestibule it is not necessary for the interior and exterior doors to open at the same time. Interior and exterior doors shall have a minimum distance between them of not less than 7 feet when in the closed position. The floor area of each vestibule shall not exceed the greater of 50 feet² or 2% of the gross conditioned floor area for that level of the building.* The exterior envelope of conditioned vestibules shall comply with the requirements for a conditioned space. The interior and exterior envelope of unconditioned vestibules shall comply with the requirements for a semi-heated space.

Exceptions:

- 1. Doors not intended to be used by the public, such as doors to storage, mechanical, electrical, or equipment rooms.**
- 2. Doors opening directly from a sleeping unit or dwelling unit.**
- 3. Doors that open directly from a space less than 3,000 feet² (298 m²) in area.**
- 4. Revolving doors.**
- 5. Doors used primarily to facilitate shipping, receiving, or material handling.**
- 6. Doors with no exterior entrance hardware.**
- 7. Doors leading solely to outdoor eating areas.**
- 8. Overhead doors.**

ASHRAE 90.1 (2013) MICHIGAN AMENDMENTS (4 of 5)

Section 6.7.2.4 System Commissioning (*Mich. Act amends system commissioning for HVAC controls for projects over 10,000 SF rather than the SF 50,000 indicated in ASHRAE 90.1 (2013).*)

R1098a. Section 6.7.2.4 of the standard is amended to read as follows:

6.7.2.4. System Commissioning. *HVAC control systems shall be tested to ensure that control elements are calibrated, adjusted, and in proper working condition. For projects larger than 10,000 ft², conditioned area, except warehouses and semiheated spaces, detailed instructions for commissioning HVAC systems (see informative appendix E) shall be provided by the designer in plans and specifications.*

ASHRAE 90.1 (2013) MICHIGAN AMENDMENTS (5 of 5)

Section 9.1.2 Lighting Alterations *(Mich. Act amends the exception for when lighting alterations needs to comply with the code during alterations to 50% of connected load rather than the 10% indicated in ASHRAE 90.1 (2013)).*

R 408.31098c (C506.4) Lighting alterations.

R1098b. Section 9.1.2 of the standard is amended to read as follows:

9.1.2. Lighting alterations.

For the alteration of any lighting system in an interior space, that space shall comply with the lighting power density (LPD) requirements of section 9 applicable to that space and the automatic shutoff requirements of section 9.4.1.1. For the alteration of any lighting system in an exterior building application, that lighting system shall comply with the lighting power density (LPD) requirements of section 9 applicable to the area illuminated by that lighting system and the applicable control requirements of sections 9.4.1.4(a) and 9.4.1.4(b). These alterations shall include all luminaires that are added, replaced, or removed. This requirement shall also be met for alterations that involve only the replacement of lamps plus ballasts. Alterations do not include routine maintenance or repair situations.

Exception: Alterations that involve less than **50%** of the connected lighting load in a space or area do not have to comply with these requirements, provided that such alterations do not increase the installed LPD.

Presenter's Note: ASHRAE 90.1 (2013) triggered compliance at 10%

ASHRAE 90.1 (2013) for use in Michigan

Bird's Eye View of changes from ASHRAE 90.1 (2013) from ASHRAE 90.1 (2007)



ASHRAE 90.1 (2013) Significant Changes (1 of 4)

Bird's Eye View

Entire Document page increase

ASHRAE 90.1 (2007) is **183 pages**

ASHRAE 90.1 (2013) is **270 pages (+47%)**

Technical Chapters 5-10 page increase

ASHRAE 90.1 (2007) **48 pages**

ASHRAE 90.1 (2013) **87 pages (+81%)**

ASHRAE 90.1 (2013) Significant Changes (2 of 4)

Bird's Eye View

As a general rule if there is a more energy efficient solution it was adopted.

Virtually every section, subsections, page, requirement and table is changed throughout.

According to DOE Energy efficiency is improved by close to 26% from the ASHRAE 90.1 (2007) standard used in Michigan until September 19, 2017.

ASHRAE 90.1 (2013) Significant Changes (3 of 4)

What makes it hard to compare:

No summary document was found to date that lays out the detailed changes from ASHRAE 90.1 (2007) to ASHRAE 90.1 (2013)

There are no sidebar markings in ASHRAE 90.1 (2013) to indicate changes from 2010 or 2007.

Appendix F does list changes from ASHRAE 90.1 (2010), but ASHRAE 90.1 (2010) was not adopted by Michigan

ASHRAE 90.1 (2013) Significant Changes (4 of 4)

Overview of Changes to ASHRAE 90.1 (2013) from ASHRAE 90.1 (2007)

The following slides touch on significant changes to ASHRAE 90.1 (2013) chapters from ASHRAE 90.1 (2007). The slides do not typically indicate actual code language or do they necessarily address all changes in a Chapter or Section. It is important that attendees review the actual code language when designing, permitting or inspecting specific projects.

ASHRAE 90.1 (2013) Structure

Layout of ASHRAE 90.1 (2013) is the same as ASHRAE 90.1 (2007)

Section 1 - Purpose

Section 2 - Scope

Section 3 - Definitions, Abbreviations, and Acronyms

Section 4 - Administration and Enforcement

Section 5 - Building Envelope

Section 6 - Heating, Ventilating, and Air Conditioning

Section 7 - Service Water Heating

Section 8 - Power

Section 9 - Lighting

Section 10 - Other Equipment

Section 11 - Energy Cost Budget Method

Section 12 - Normative References

- A. Rated R-Value of Insulation and Assembly U-Factor, C-Factor, and F-Factor Determinations
- B. Building Envelope Climate Criteria
- C. Methodology for Building Envelope Trade-Off Option in Subsection 5.6
- D. Climatic Data
- E. Informative References –not adopted by Michigan
- F. Addenda Description Information not adopted by Michigan
- G. Performance Rating Method

ASHRAE 90.1 (2013) Significant Changes – Section 1

Section 1 – Purpose

Lays out the purpose of the document

New changes include:

Energy efficiency requirements for design, construction and a *“plan for operation and maintenance”*.

“Utilization of on-site renewable energy resources”

The references to a “plan for operation and maintenance” and “onsite renewable energy” are new and reflect some new emphasis areas in the code.

ASHRAE 90.1 (2013) Significant Changes – Section 2 (1 of 2)

Section 2 - Scope

Lays out when the code applies and includes

- “New buildings and their systems
- New portions of buildings and their systems (additions)
- New systems and equipment in existing buildings (alterations)”
- *“New equipment and building systems identified in the standard that are part of industrial or manufacturing processes”*

Industrial and manufacturing process are now addressed in certain sections but only to a limited extent

ASHRAE 90.1 (2013) Significant Changes – Section 2 (2 of 2)

Section 2 - Scope

The standard does not apply to:

- Single-family, multifamily of three stories or less, manufactured or modular homes
- Buildings that don't use electricity or fossil fuel

ASHRAE 90.1 (2013) Significant Changes – Section 3 (1 of 2)

*"It depends upon **what the meaning** of the word 'is' is."*

Section 3 - Definitions, Abbreviations, and Acronyms

- This section is in addition to the IECC 2015 Chapter 2 definitions adopted by Michigan.
- *There are significant changes to the definitions in ASHRAE 90.1 (2013) from ASHRAE 90.1 (2007)*

ASHRAE 90.1 (2013) Significant Changes - Section 3 (2 of 2)

Section 3 - Definitions, Abbreviations, and Acronyms

- Page count for definitions in this section went from 10 in ASHRAE 90.1 (2007) to 18 in ASHRAE 90.1 2013)
- Approximately 100 new or modified definitions
- Some are highly technical and reflect new code provisions such as daylighting, sensible heat and cooling panels, computer rooms and various controls.

Section 4 - Administration and Enforcement

Section addresses Scope for:

- New buildings
- Additions to existing buildings
- Alterations to existing buildings
- Replacement of portions of existing buildings
- Administrative requirements
- Alternative Materials, methods of construction
- Validity
- Other Laws
- Reference Standards

ASHRAE 90.1 (2013) Significant Changes – Section 4 (2 of 3)

Section 4 – (Continued) addresses Scope for:

- Normative Appendices
- Compliance Paths
- Compliance Documentation
- Construction details
- Supplemental Information
- Manuals
- Labeling of Material and Equipment
- Inspections

ASHRAE 90.1 (2013) Significant Changes – Section 4 (3 of 3)

Section 4 – (Continued)

- *Inspection requirements under section 4.2.2 are changed to include the requirement to inspect “continuous air barriers after installation but before concealment.”*
- *Also note that Section 4.1.1.3 Alterations is also impacted by Michigan’s adoption and amending of IECC 2015 Section 5.3.1 (referred to as 5.1.3)*

There are no other significant changes to Section 4

ASHRAE 90.1 (2013) Significant Changes – Technical Chapters

Typical Technical Chapter Layout-

Technical Sections 5,6,7,8,9, and 10

- General (Section - .1)
- Compliance Methods (Section - .2)
- Simplified Building (Section - .3)
- Mandatory Provisions (Section - .4)
- Prescriptive Path (Section - .5)
- Alternate Compliance Path (Section - .6)
- Submittals (Section -.7)
- Product Information and Installation (Section - .8)
- Tables

Role and Structure (1 of 2)

Compliance Paths

- Mandatory Provisions (must meet these)

Choose one of the following:

- Prescriptive Approach
- Tradeoff (COMcheck)
- Simplified (for some HVAC systems)
- Whole Building Simulation (Cost Budget Method)
- ASHRAE Appendix G for LEED projects
- “Above Code Programs”(Energy Star Version 3 or ICC 700-2012 Silver Rating)

Demonstrate Compliance

Prescriptive

Trade-off

Performance

“Prescriptive
Packages
Approach”

“Trade-off
Approach”

“Performance
Approach”

Residential Data Collection Checklist
2009 International Energy Conservation Code
Edition Zero 2

Date: _____ Name of Evaluator(s): _____

Building Name & Address: _____ Conditioned Floor Area: _____ sq ft

Building Contact Name: _____ Phone: _____ Email: _____

Compliance Approach: Prescriptive (IECC 1.2 or 402.1.3) Use Trade-Off (402.1.4) Building Performance (402)

State: _____ Jurisdiction: _____

Building Type: 1- and 3-Family, Detached 3- Family, Attached 4- Family, Attached 5- Family, Attached

Item Number	Description	Code	Code Value	Verified Value			Complies
				Y	N	N/A	
FO1 (402.2.8, 503.2)	Foundation Inspection Slab edge insulation R-value installed per manufacturer's instructions.	FO1 (402.2.8, 503.2)	Unheated R-5 Heated R-5	<input type="checkbox"/>	<input type="checkbox"/>	<input type="checkbox"/>	<input type="checkbox"/>
FO2 (402.2.6)	Slab edge insulation depth/length	FO2 (402.2.6)	Heated: 2 R	<input type="checkbox"/>	<input type="checkbox"/>	<input type="checkbox"/>	<input type="checkbox"/>
FO3 (402.1.1, 503.2)	Basement wall exterior insulation R-value installed per manufacturer's instructions.	FO3 (402.1.1, 503.2)	R-5	<input type="checkbox"/>	<input type="checkbox"/>	<input type="checkbox"/>	<input type="checkbox"/>
FO4 (402.2.7)	Basement wall exterior insulation depth	FO4 (402.2.7)	10 R, or to basement floor	<input type="checkbox"/>	<input type="checkbox"/>	<input type="checkbox"/>	<input type="checkbox"/>
FO5 (402.2.9, 503.2)	Crawl space wall insulation R-value installed per manufacturer's instructions.	FO5 (402.2.9, 503.2)	R-5 (cove) R-1.5 (cavity) R-5	<input type="checkbox"/>	<input type="checkbox"/>	<input type="checkbox"/>	<input type="checkbox"/>
FO6 (403.4)	Snow melt controls	FO6 (403.4)		<input type="checkbox"/>	<input type="checkbox"/>	<input type="checkbox"/>	<input type="checkbox"/>
FO7 (403.2.1)	Insulation protection	FO7 (403.2.1)		<input type="checkbox"/>	<input type="checkbox"/>	<input type="checkbox"/>	<input type="checkbox"/>

Additional Comments: _____



Role and Structure (2 of 2)

Compliance “Exceptions”

The code provides detailed requirements and then provide “exceptions” and certain conditions

- For small buildings
- For low energy use buildings
- When meeting other optional provisions

ASHRAE 90.1 (2013) Significant Changes - Section 10 (1 of 6)

Section 10 - Other Equipment

General (Section 10.1) - no significant changes

Compliance Paths (Section 10.2) - no significant changes

Simplified Building (Section 10.3) - not used

ASHRAE 90.1 (2013) Significant Changes - Section 10 (2 of 6)

Section 10 - Other Equipment

Mandatory Provisions (Section 10.4) –changes and addition of subsections

10.4.1 Electric Motors- changed language for motor efficiencies and reference to Tables 10.8-1 to 10.8-6

10.4.2 Service Water Booster Pump -requirements added

Section 10 - Other Equipment

Mandatory Provisions (Section 10.4) –changes and addition of subsections

10.4.3 Elevators-subsection added laying out requirements for elevators

- *10.4.3.1 Lighting - new requirement added*
- *10.4.3.2 Ventilation Power Limitations –new requirement added*
- *10.4.3.3 Standby Mode- new requirement*

Section 10 - Other Equipment

Mandatory Provisions (Section 10.4) –changes and addition of subsections

10.4.4 Escalators and Moving Walks-subsection added requirement for automatic slowing when not conveying passengers- new requirement added

Section 10 - Other Equipment

Mandatory Provisions (Section 10.4) –changes and addition of subsections

10.4.5 Whole Building Energy Monitoring –new requirement added

- 10.4.5.1 Monitoring-new requirement added*
- 10.4.5.2 Recording and Reporting-new requirement added*

Exceptions to 10.4.5.1 and 10.4.5.2 were added

Section 10 - Other Equipment

- Prescriptive Compliance Path (Section 10.5) – not used
- Alternative Compliance Path (Section 10.6) – not used
- Submittals (Section 10.7) – not used
- Product Information and Installation Requirements (Section 10.8) – no information

Tables 10.8-1 to Tables 10.8.6 for various motor type efficiencies added or modified

Section 7 Service Water Heating

- ✓ General (Section 7.1)
- ✓ Compliance Path(s) (Section 7.2)
- ✓ Mandatory Provisions (Section 7.4)
 - Load calculations
 - Equipment efficiency
 - *Service hot water piping insulation*
 - System controls
 - Pools
 - Heat traps
- ✓ Prescriptive Path (Section 7.5)
 - Space heating and water heating
 - Service water heating equipment
 - *Buildings with high-capacity service water heating systems*
- ✓ Submittals (Section 7.7)
- ✓ Product Information (Section 7.8)



ASHRAE 90.1 (2013) Significant Changes – Section 7 (1 of 4)

Section 7- Service Water Heating

- General (Section 7.1) - no significant change
- Compliance Paths (Section 7.2) - no significant change
- Simplified Building (Section 7.3) - not Used

Section 7 – 7.4.4 Service Water Heating System Controls

- ✓ Temperature Controls
- ✓ Temperature Maintenance Controls
- ✓ Outlet Temperature Controls
- ✓ Circulating Pump Controls



U.S. Department of Energy (2010)

Section 7-Service Water Heating

Mandatory Provisions (Section 7.4)

- 7.4.3 Service Water Piping-refers to Table 6.8.3-1.

**Virtually all piping insulation thickness requirements have increased.*

**Exceptions for areas not requiring insulation have been modified*

Section 7 – 7.4.3 Service Hot Water Piping Insulation

Insulate the following per Table 6.8.3-1

- Circulating water heater
 - Recirculating system piping, including supply and return piping
- Nonrecirculating storage system
 - First 8 ft of outlet piping
 - Inlet pipe between storage tank and heat trap
- Externally-heated pipes (*heat trace or impedance heating*)



Section 7-Service Water Heating

Prescriptive Building Envelope Option (Section 7.5)

- *7.5.3 Buildings with High Heat-Capacity Service Water Heating Systems-section added efficiency requirements and exceptions*

Alternative Compliance Path (Section 7.6) –not used

Section 7-Service Water Heating

Submittals (Section 7.7)-no significant changes
Product Information and Installation Requirements
(Section 7.8) –no requirements listed

Table 7.8 Performance Requirements for Water-Heating Equipment has some changes

Section 7 – 7.4.5 Pools

- Pool heaters to have readily accessible on-off switch
- Pool heaters fired by natural gas can NOT have continuously burning pilot lights
- Vapor retardant pool covers required (unless recovered or solar heat)
- Time switches required for both heaters and pumps



U.S. Department of Energy (2010)

ASHRAE 90.1 (2013) Significant Changes – Section 8 (1 of 4)

Section 8 - Power

General (Section 8.1) - minor changes reflecting clarifications of how this standard applies to additions and alterations

Compliance Paths (Section 8.2) - no significant change

Simplified/Small Building Option (Section 8.3) - not used

ASHRAE 90.1 (2013) Significant Changes – Section 8 (2 of 4)

Section 8- Power

Mandatory Provisions (Section 8.4)

- ***8.4.1 Voltage drop- minor change to exceptions for “feeder conductors and branch circuits for circuits dedicated to emergency services***

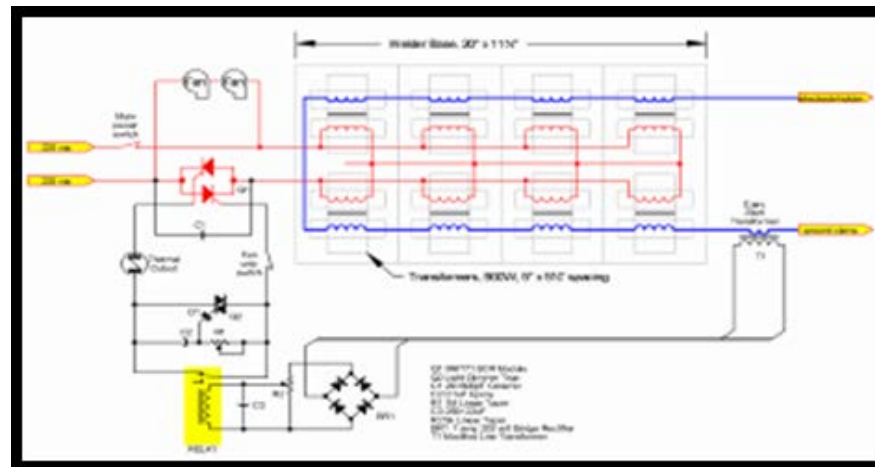

Section 8- Power

Mandatory Provisions (Section 8.4)

- *8.4.1 Voltage drop- minor change to exceptions for “feeder conductors and branch circuits for circuits dedicated to emergency services*

Michigan Deleted the following sections

- *8.4.2 Automatic receptacle control*
- *8.4.3 Electrical Energy Monitoring*
- *8.4.3.1 Monitoring*
- *8.4.3.2 Recording and Record Keeping*

ASHRAE 90.1 (2013) Significant Changes – Section 8 (4 of 4)

Section 8- Power

Mandatory Provisions (Section 8.4)

- ***8.4.4 Low Voltage Dry-Type Distribution Transformers (new section added)***

Prescriptive Path (Section 8.5)- not used

Alternate Compliance Path (Section 8.6) – not used

Submittals (Section 8.7) -no significant change

Product Information and Installation Requirements (Section 8.8) – not used

Table 8.4.4-added and shows efficiency levels for Low Voltage Dry Type Distribution Transformers

Power Submittals (*Section 8.7*)

Owner gets information about the building's electrical system

- Record drawings of actual installation within 30 days (*Section 8.7.1*)
 - Single-line diagram of electrical distribution system
 - Floor plans showing location and areas served for all distribution
- Manuals (*Section 8.7.2*):
 - Submittal data stating equipment rating
 - O&M manuals for equipment
 - Qualified service agency
 - Complete narrative of system as it's normally intended to operate



U.S. Department of Energy (2010)



U.S. Department of Energy (2010)

ASHRAE 90.1 (2013) Significant Changes – Section 5 (1 of 12)

Section 5- Building Envelope

ASHRAE 90.1 (2013) 17 pages +31% ASHRAE 90.2 (2007) is 13 pages

General (Section 5.1)-several changes

5.1.2 Space Conditioning Categories

- *5.1.2.2 specifies minimum skylight requirements also apply to unconditioned spaces*

5.1.3 Envelope Alterations-Michigan has amended this section to reflect the roof recovering language for roofs with R-20 and when it would necessitate raising non-energy related elements such as curbs and flashings.

5.1.4 Climate

- *5.1.4.2 International Locations- slight language changes but does not apply in Michigan*

Compliance Methods (Section 5.2) – no significant changes

Simplified Building (Section 5.3) Not Used

Section 5 – 5.1.2 Space-Conditioning Categories

Separate envelope component requirements apply to three types of conditioned spaces

- Nonresidential
- Residential
- Semiheated

Residential spaces are used for dwelling

Semiheated spaces are heated, but not to comfort levels, and not cooled

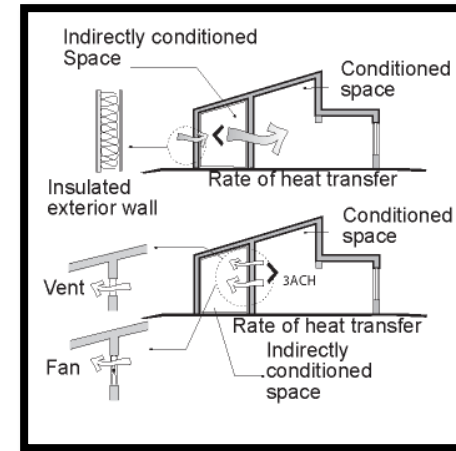
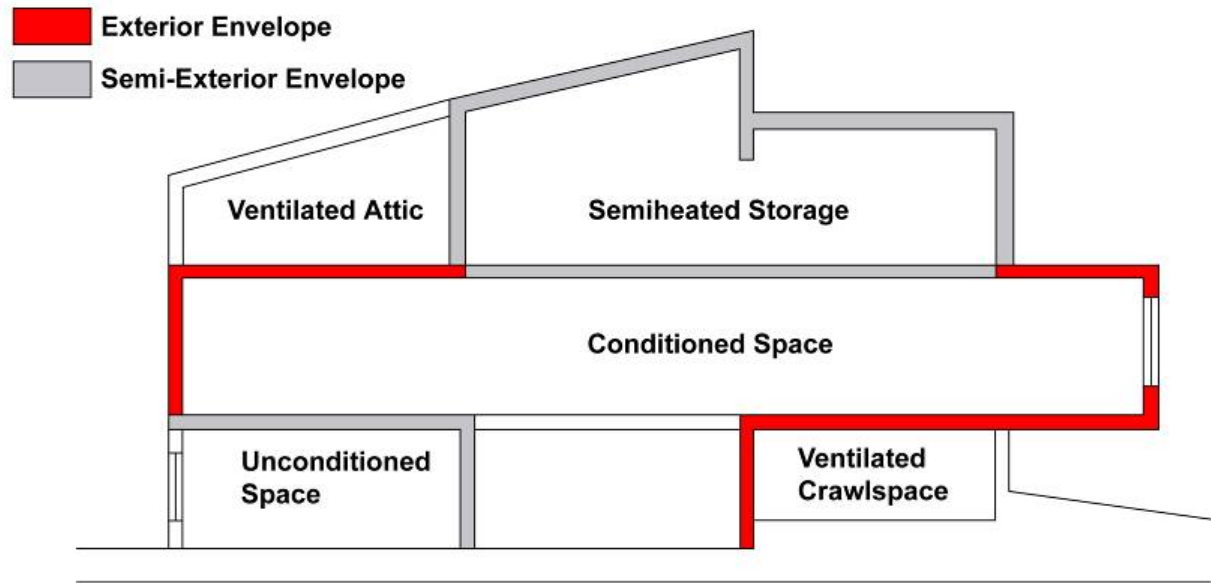

Figure 5-A

Examples of Indirectly Conditioned Spaces
(User's Manual – 90.1.-2013)

Section 5 Building Envelope



Mandatory Provisions

- Insulation (*Section 5.8.1*)
 - Labeling (*Section 5.8.1.1*)
 - Substantial Contact (*Section 5.8.1.5*)
 - Recessed Equipment (*Section 5.8.1.6*)
 - Insulation Protection (*Section 5.8.1.7*)
 - Insulation Above Suspended Ceilings (*Section 5.8.1.8*)
- *Fenestration and Doors (Section 5.8.2)*
- *Air Leakage (Section 5.4.3)*

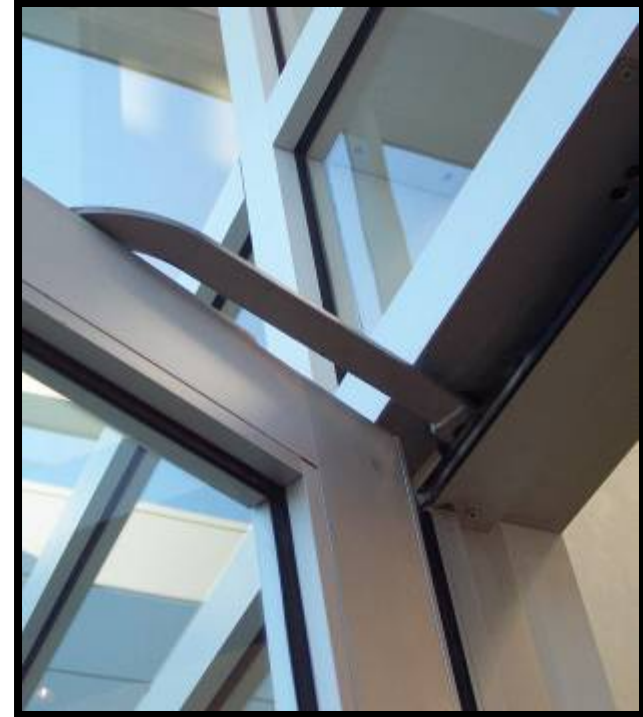

U.S. Department of Energy (2010)

Section 5 – 5.4 Mandatory Provisions

- ✓ Fenestration and Doors (*Section 5.4.2 that refers to 5.8.2*)
- ✓ Air Leakage (*Section 5.4.3*)



Photo courtesy of Ken Baker, K energy

Section 5- Building Envelope

Mandatory Provisions (Section 5.4) –many changes

5.4.3 Air Leakage

- *5.4.3.1 Continuous Air Barrier-significant change. Adds new requirement for continuous air barrier, air barrier design and acceptable materials*
- *5.5.3.2 Fenestration and Doors- Adds air leakage requirements and reference standards various fenestration products such as glazing, doors and skylights*

Section 5 – 5.4.3 Air Leakage

- Continuous air barrier
- Fenestration and doors
- Loading dock weather seals
- Vestibules



Thermal Envelope- Changes

Air Barriers – good information sources Building Science Corp

The screenshot shows a web browser window with the address bar displaying <http://buildingscience.com/doc>. The search bar contains the text "air barriers". The page header features the Building Science Corporation logo and navigation links: "About | Portfolio | Conversations | Contact | Log in". A secondary navigation bar includes "Our Services", "Articles and Papers", "Guidance", "Popular Topics", "Bookstore", and "Events and Training". The main content area shows the breadcrumb "Home | Building Science Digests | BSD-104: Understanding Air Barriers" and the article title "BSD-104: Understanding Air Barriers" by Joseph Lstiburek, dated OCTOBER 24, 2006. Below the title, there are two tabs labeled "Very Cold" and "Cold". On the right side, there are sections for "Upcoming Events" (listing "Building Science Fundamentals" and "Renovation and Rehabilitation") and "Related Books" (listing "Builder's Guide to Mixed-Humid Climates").

<http://buildingscience.com/documents/digests/bsd-104-understanding-air-barriers> visited Jan 21, 2016

Section 5 – 5.4.3.1 -Continuous Air Barrier

- Continuous air barrier required except in:
 - Semiheated spaces in *climate zones 1-6*
 - Single wythe concrete masonry buildings in *climate zone 2B*
- Plans
 - Air barrier components identified or noted in construction documents
 - Joints, intersections, and penetrations of air barrier components (incl. lighting fixtures) detailed
- To extend over all surfaces of building envelope
 - At lowest floor, exterior walls, and ceiling or roof
- Designed to resist positive and negative pressures
 - Wind, stack effect, and mechanical ventilation

Section 5 – 5.4.3.1.2 Air Barrier Installation

The following areas are to be wrapped, sealed, caulked, gasketed, or taped

- Joints around fenestration and door frames
 - Junctions between walls
 - And foundations
 - At building corners
 - And roofs or ceilings
- Penetrations for roofs, walls, and floors
- Building assemblies used as ducts or plenums
- Joints, seams, connections between planes, and other changes in air barrier materials



Section 5 – 5.4.3.1.3 Air Barrier Materials

Material	Thickness (minimum)
Plywood	3/8 in.
Oriented strand board	3/8 in.
Extruded polystyrene insulation board	½ in.
Foil-faced urethane insulation board	½ in.
Exterior gypsum sheathing or interior gypsum board	½ in.
Cement board	½ in.
Built up roofing membrane	
Modified bituminous roof membrane	
Fully adhered single-ply roof membrane	
A Portland cement/sand parge, stucco, or gypsum plaster	½ in.
Cast-in-place and precast concrete	
Sheet metal	
Closed cell 2 lb/ft ³ nominal density spray polyurethane foam	1 in.

Section 5 – 5.4.3.2 Air Leakage – Fenestration

Product	cfm/ft ²	Procedure	psf
Glazed swinging entrance doors and revolving doors	1.0	AAMA/WDMA/CSA 101/I.S.2/A440, NFRC 400, or ASTM E283	1.57
Curtainwall and storefront glazing	0.06	NFRC 400 or ASTM E283	1.57
Unit skylights with condensation weepage openings	0.3	AAMA/WDMA/CSA 101/I.S.2/A440 or NFRC 400	1.57
Unit skylights with condensation weepage openings	0.5	AAMA/WDMA/CSA 101/I.S.2/A440	6.24
Nonswinging doors for vehicular access and material transportation (min. opening of 32 in/s)	1.3	ANSI/DASMA 105, NFRC 400, or ASTM E283	1.57
Nonswinging opaque doors, glazed sectional garage doors, and upward acting nonswinging glazed doors	0.4	ANSI/DASMA 105, NFRC 400, or ASTM E283	1.57
All other products	0.2	AAMA/WDMA/CSA 101/I.S.2/A440 or NFRC 400	1.57
All other products	0.3	AAMA/WDMA/CSA 101/I.S.2/A440	6.24

Exceptions

- Field-fabricated fenestration and doors
- Metal coiling doors in semiheated spaces
In climate zones 1-6
- Products in buildings that comply with a whole building air leakage rate of 0.4 cfm/ft² under pressure differential of 0.3 in. H₂O, 1.57 psf per ASTM E779

Section 5 – 5.4.3.3 Loading Dock Weather seals

In climate zones 4-8

- Cargo doors and loading dock doors equipped with weather seals
 - To restrict infiltration when vehicles are parked in the loading dock/doorway



Section 5- Building Envelope

Mandatory Provisions (Section 5.4)

5.3.4. Vestibules - requires vestibules for building entrances, sets maximum size for vestibules at 50sf or 2% of gross conditioned floor area for level served. Michigan has amended the exceptions in this section.

- 5.4.3.1 addresses vestibules for large spaces greater than 40,000 sf when equipped with automatic doors and requires they have a minimum 16 ft between doors.*

Section 5 Air Leakage – Vestibules Exceptions

Exceptions:

- 1. Doors not intended to be used by the public, such as doors to storage, mechanical, electrical, or equipment rooms.
- 2. Doors opening directly from a sleeping unit or dwelling unit.
- 3. Doors that open directly from a space less than 3,000 feet² (298 m²) in area.
- 4. Revolving doors.
- 5. Doors used primarily to facilitate shipping, receiving, or material handling.
- 6. Doors with no exterior entrance hardware.
- 7. Doors leading solely to outdoor



Section 5- Building Envelope

Prescriptive Building Envelope Option (Section 5.5)

5.5.1- requires compliance with the envelope requirements for residential or non-residential and refers to Building Envelope Requirements for Climate Zones Table 5.5-1 to 5-5-8.

There are substantial changes to these envelope tables. Almost all values for Zones 5, 6 and 7 are changed and call for lower U factors and higher R values.

Building Envelope Requirements (Table 5.5-5)

Climate Zone 5

- Nonresidential Examples See Tables for Zones 5,6,7
 - Roofs: insulation entirely above deck = $R-30$ (R-20.0 c.i.)
 - Roofs: Attic and other = $R-49$ (R-38.0)
 - Above-Grade Walls: mass = $R-11.4$ c.i. (R-11.4 c.i.)
 - Above-Grade Walls: steel-framed = $R-13+R-10$ c.i. (R-13.0 + R-7.5 c.i.)
 - Above-Grade Walls: wood-framed = $R-13+ R-7.5$ c.i. or $R-19 + R-5$ c.i. (R-13.0 + R-3.8 c.i)
 - Below-Grade Walls: below-grade wall = $R- 7.5$ c.i. (R-7.5 c.i.)
 - Floors: mass = $R-14.6$ c.i. (R-10.4 c.i.)
 - Floors: steel joist = $R-30$ (R-30.0)
 - Slab-On-Grade Floors: heated = R-20 for 48: (R-15 for 24 in.)
 - Doors: nonswinging = $U-0.500$ (U-0.500)

Presenter's note: () = 2007 ASHRAE 90.1 values

Section 5- Building Envelope

Prescriptive Building Envelope Option (Section 5.5)

5.5.3.1 Roof Insulation

- *5.5.3.1.1 Roof Solar Reflectance and Thermal Emittance- section changed but does not apply in Michigan it only applies in Climate Zones 1-3.*

5.5.3.2 Above Grade Walls- exception requirements for mass walls are added

Section 5 – 5.5 Prescriptive Envelope Option

Each envelope component must separately meet requirements

Opaque Areas (5.5.3)

Fenestration (5.5.4)

- $WWR \leq 40\%$ of gross wall area
- Skylight-roof ratio $\leq 3\%$ of roof area

Prescriptive requirements for each component specified by climate zone and space conditioning category (Tables 5.5-1 through 5.5-8)

- Insulation levels for roofs, walls, floors and doors
- Fenestration criteria for windows, glazed doors and skylights

Section 5 – 5.5.1 - Opaque

TABLE 5.5-5 Building Envelope Requirements For Climate Zone 5 (A, B, C)*

Opaque Elements	Nonresidential		Residential		Semiheated	
	Assembly Maximum	Insulation Min. R-Value	Assembly Maximum	Insulation Min. R-Value	Assembly Maximum	Insulation Min. R-Value
Roofs	Nonresidential		Residential		Semiheated	
	Assembly Maximum	Insulation Min. R-Value	Assembly Maximum	Insulation Min. R-Value	Assembly Maximum	Insulation Min. R-Value
Roofs						
Insulation Entirely above Deck	U-0.032	R-30 c.i.	U-0.032	R-30 c.i.	U-0.063	R-15 c.i.
Metal Building	U-0.037	R-19+R-11 Ls or R-25+R-8 Ls	U-0.037	R-19+R-11 Ls or R-25+R-8 Ls	U-0.082	R-19
Attic and Other	U-0.021	R-49	U-0.021	R-49	U-0.034	R-30

Heated	F-0.688	R-20 for 48 in.	F-0.688	R-20 for 48 in.	F-0.900	R-19 for 24 in.
<i>Opaque Doors</i>						
Swinging	U-0.500		U-0.500		U-0.700	
Nonswinging	U-0.500		U-0.500		U-0.450	

Reference Table 5.5-5 on page 31 in 90.1-2013

Section 5 – 5.5.3.1 Roof Insulation (cont'd)

Three types of roofs are defined

- ✓ Roofs with insulation entirely above deck
 - R-value is for continuous insulation
 - Interruptions for mechanical equipment \leq 1% of surface of the total roof area
- ✓ Metal building roofs
 - First value is for insulation
 - draped over purlins and then compressed when metal spanning members attached or
 - hung between purlins provided there's a min. of 1" thermal break between purlins and metal spanning members
 - Second value is for double-layer installations with insulation installed parallel to the purlins
- ✓ Attics and other roofs
 - R-value is for insulation installed both inside and outside the roof or entirely inside the roof cavity

Section 5 – 5.8.1 Insulation Installation

- ✓ Per manufacturer's instructions
- ✓ Achieve rated R-value
- ✓ No open-blown or poured loose-fill insulation when ceiling slope is $> 3/12$
- ✓ If eave vents installed
 - Provide baffling of air vents to deflect incoming air above the surface of the insulation
 - Metal buildings **Exception**
 - if roof and wall insulation is compressed between roof or wall skin and the structure

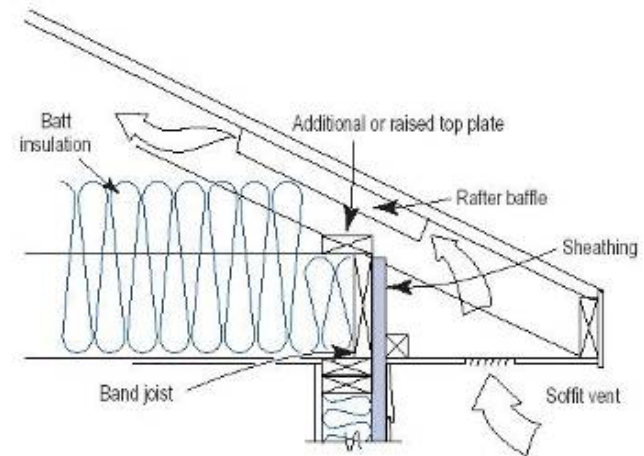

Section 5 High Albedo Roof - *Example*



Not required for Michigan but ay still be needed as part of a LEED project

Source: slide modified from www.energycodes.gov ANSI/ASHRAE Standard 90.1 2013 ENVELOPE - VISITED SEPT. 5, 2017

Section 5 Above-Grade Wall Insulation

Four types of walls are defined (cont'd)

- **Metal building wall R-value**
 - for insulation compressed between metal wall panels and the steel structure
- **Steel-framed wall R-value**
 - for uncompressed insulation installed in the cavity between steel studs; also acceptable to be continuous insulation uninterrupted by studs
- **Wood-framed and other R-value**
 - for uncompressed insulation installed in the cavity between wood studs; also acceptable to be continuous insulation uninterrupted by studs



Section 5 – 5.5.3.3 Below-Grade Wall Insulation

Meet or exceed values in appropriate table for climate zone

R-value is for continuous insulation

Exception

- If framing is used, compliance is based on maximum assembly C-factor

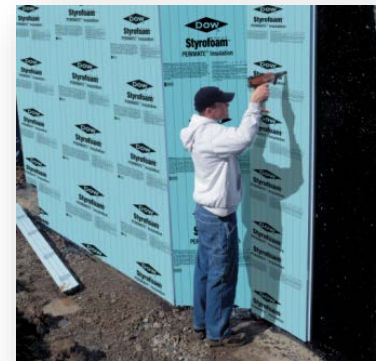

Photo courtesy of Dow Building Solutions

Section 5 – 5.5.3.5 - SOG Floor Insulation

Meet or exceed values in appropriate table for climate zone *(includes R-value and depth or width of insulation)*

Be installed around the perimeter to the distance specified

- **Inside foundation wall** – extend downward from top of slab a minimum distance specified or to the top of the footing, whichever is less
- **Outside foundation wall** – extend from top of the slab or downward to at least the bottom of the slab and then horizontally to a minimum distance specified



Floor Insulation (Section 5.5.3.4)

- Meet or exceed values in appropriate table for climate zone
- 3 classes of floors over unconditioned space are defined:
 - Mass floors
 - R-value is for continuous insulation
 - If framing is used, compliance is based on maximum assembly U-factor
 - Steel-joist floors
 - R-value is for uncompressed insulation or spray-on insulation, but is also acceptable for continuous insulation
 - Wood-framed and others
 - R-value is for uncompressed insulation, but is also acceptable for continuous insulation

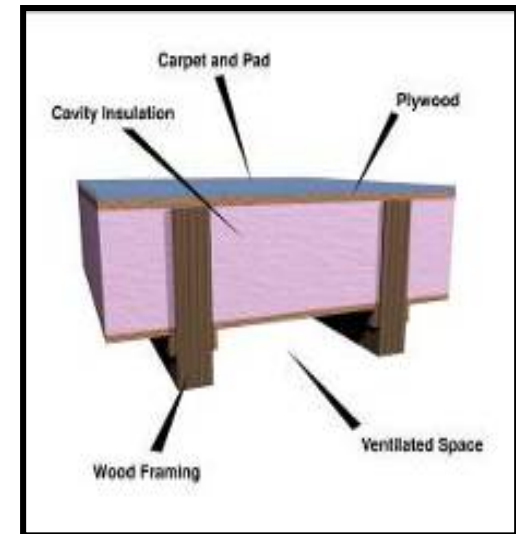

U.S. Department of Energy (2010)

Section 5- Building Envelope

Prescriptive Building Envelope Option (Section 5.5)

5.5.4 Fenestration

- *5.5.4.1 General-stipulates that U factors, SHGC and VT/SHGC be demonstrated for the whole product.*
- *Requires wall and roof areas of fenestration to be calculated separately for each space conditioning category*

Fenestration Area

- Total vertical fenestration area to be $< 40\%$ of gross wall area (*Section 5.5.4.2.1*)
 - Including both fixed and operable vertical fenestration
- Total skylight area to be $< 3\%$ of gross roof area (*Section 5.5.4.2.2*)
 - Including glass skylights, plastic skylights with a curb, and all skylights without a curb



U.S. Department of Energy (2010)

Section 5 – 5.5.4.3 and 5.8.2.3 Fenestration U-Factor

U-factor not greater than specified in Tables 5.5-1 through 5.5-8

– For *climate zone 5*

- *U-0.32* for non-metal framing (U=0.35 in 2007)
- *U-0.42* for fixed metal framing (U=0.45 in 2007)
- *U-0.50* for operable metal framing (U=0.55 in 2007)
- *U-0.77* for entrance door metal framing (U=0.7 swinging and 0.5 non-swinging in 2007)
- *U-0.50* for Skylights (Varies with application in 2007)

Labeled and certified by manufacturer

Exceptions

- A8.1 acceptable for skylights, A8.2 acceptable for other vertical fenestration, and A7 acceptable for opaque doors
- ANSI/DASMA 105 acceptable for garage doors

Fenestration and Doors

U-factors (Section 5.8.2.4)

- NFRC 100 or
- Assemblies listed in Appendix A

SHGC (Section 5.8.2.5)

- NFRC 200 or
- Assemblies listed in Appendix A

Visible Light Transmittance (Section 5.8.2.6)

- NFRC 200 when building envelope trade-off option is used



U.S. Department of Energy (2010)

Using the Evaluation Checklists: Fenestration



National Fenestration
Rating Council®

CERTIFIED

**World's Best
Window Co.**

Millennium 2000+
Vinyl-Clad Wood Frame
Double Glazing • Argon Fill • Low E
Product Type: **Vertical Slider**

ENERGY PERFORMANCE RATINGS

U-Factor (U.S./I-P)

0.30

Solar Heat Gain Coefficient

0.30

ADDITIONAL PERFORMANCE RATINGS

Visible Transmittance

0.51

Air Leakage (U.S./I-P)

0.2

Manufacturer stipulates that these ratings conform to applicable NFRC procedures for determining whole product performance. NFRC ratings are determined for a fixed set of environmental conditions and a specific product size. NFRC does not recommend any product and does not warrant the suitability of any product for any specific use. Consult manufacturer's literature for other product performance information.
www.nfrc.org

FR8

[5.8.2.1]²

Fenestration products rated in accordance with NFRC.

Section 5- Building Envelope

Prescriptive Building Envelope Option (Section 5.5)

5.5.4.2 Fenestration Areas

5.5.4.2.2-Maximum Skylight Fenestration Area sets (0-3%) maximum skylight areas from Tables 5.5-1 to 5.5-8 and provides an exception for 6% of gross roof area for certain daylight areas

5.5.4.2.3-Minimum Skylight Fenestration Area -establishes minimum skylight for certain functional spaces greater than 2,500 sf and meeting various roof/ceiling conditions. This section also provides exceptions.

Section 5- Building Envelope

Prescriptive Building Envelope Option (Section 5.5)

5.5.4.4 Fenestration Solar Heat Gain Coefficient (SHGC)- sets the SHGC requirements as meeting Tables 5.5-1 to 5.5-8 and identifies exceptions

5.5.4.5 Fenestration Orientation- puts limitations on how much fenestration can be located on the West or East facades through calculations based on total wall area and West and East wall areas.

5.5.4.6 Visible Light Transmission-new section sets VT/SHGC per Tables 5.5-1 to 5.5-8 when using automatic daylight controls in accordance with 9.4.1.1(e)

Section 5 – 5.5.4.5 - Fenestration Orientation

Two options to comply:

$$a) A_w \leq \frac{A_t}{4} \text{ and } A_e \leq \frac{A_t}{4}$$

$$b) A_w \times SHGC_w \leq \frac{A_t \times SHGC_c}{4} \text{ and } A_e \times SHGC_e \leq \frac{A_t \times SHGC_c}{4}$$

Where,

A_w and $SHGC_w$ = west-oriented vertical fenestration area and SHGC

A_e and $SHGC_e$ = east-oriented vertical fenestration area and SHGC

A_t = total vertical fenestration area

$SHGC_c$ = SHGC criteria in Tables 5.5-1 through 5.5-8

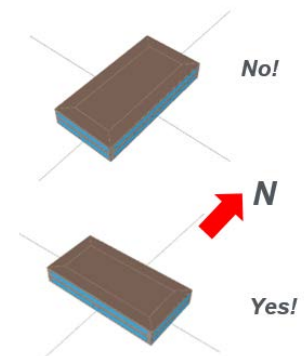

Exceptions

- *Complies with Exception 3 of Section 5.5.4.4.1*
- *Buildings shaded by other buildings within 20 ft to the south which is at least ½ as tall as the proposed building*
- *Buildings with shade on 75% of the west and east*
- *Alterations and additions that don't increase vertical fenestration area*
- *Buildings where west- and east-oriented vertical fenestration area < 20% of gross wall area for each of those facades and SHGC on those facades < 90% of $SHGC_c$*
- *In climate zone 8*

Section 5 – 5.5.4 Fenestration

Criteria apply to fenestration, including windows, glass doors, glass block, plastic panels, and skylights

- specified by fenestration type, space conditioning category and by climate zone

Compliance with values in Tables 5.5-1 through 5.5-8

- U-factor not greater than specified
- SHGC not greater than specified
- *Meet or exceed minimum VT/SHGC*
- Use NFRC ratings or default values in Appendix A
- Area weighting allowed within same class of construction and space conditioning category



Section 5 – 5.5.4.2.3 Minimum Skylight Area

Minimum skylight area must be provided in enclosed spaces that are

- $\geq 2,500$ ft²
- In spaces with ceiling height > 15 ft and
- Space types
 - Office
 - Lobby
 - Atrium
 - Concourse
 - Corridor
 - Storage (*incl. nonrefrigerated warehouse*)
 - Gymnasium/*fitness/exercise*
 - *Area, playing area*
 - *Gymnasium seating*
 - Convention *exhibit/event space*
 - Courtroom
 - Automotive space
 - *Fire state engine room*
 - Manufacturing
 - *Corridor/transition and bay areas*
 - Retail
 - *Library reading and stack areas*
 - Distribution/sorting area
 - Transportation
 - *Baggage and seating areas*
 - Workshop

Section 5: Visible Transmittance/SHGC Ratio

When automatic daylighting controls are required per 9.4.1.1 (e) or (f)

- fenestration to have a ratio of VT/SHGC not less than listed in Tables 5.5-1 through 5.5-8 (>1.1 for all climate zones)

Exceptions:

- Can have a light-to-solar-gain ratio (LSG) of not less than 1.25
 - center-of-glass SHGC and VT determined per NFRC 300 and NFRC 301 by independent lab or included in a database published by a government agency and certified by a manufacturer
- Fenestration not covered in scope of NFRC 200
- Enclosed spaces
 - where daylight area under rooftop monitors is > 50% of enclosed floor area
 - with skylights complying with 5.5.4.2.3
 - where sidelighting effective aperture is ≥ 0.15
- Dynamic glazing
 - VT/SHGC ratio and LSG determined using maximum VT and maximum SHGC
 - Considered separately from other fenestration; cannot include dynamic glazing with other fenestration for area-weighted averaging

Section 5 – 5.5.4.4 Fenestration SHGC

Vertical fenestration (5.5.4.4.1)

- SHGC values < Table value for appropriate total vertical fenestration area

Exceptions

- For vertical fenestration only, the SHGC in the proposed building can be reduced by using the multipliers in Table 5.5.4.4.1 for fenestration shaded by permanent projections that will last as long as the building itself
- For vertical fenestration shaded by partially opaque permanent projections that will last as long as the building itself, can reduce the PF by multiplying by values in Section 5.5.4.4.1
- Street-level exception only applies when using the prescriptive compliance option
- Dynamic glazing cannot be area-weighted with other fenestration and minimum SHGC of dynamic glazing shall be used to show compliance for dynamic glazing
- North-oriented vertical fenestration allowed to have SHGC lower than that specified Tables 5.5-1 through 5.5-8 by 0.05

Information – Overhangs

Standard credits
permanent overhangs by
adjustment to SHGC

Size of overhang is
determined by projection
factor

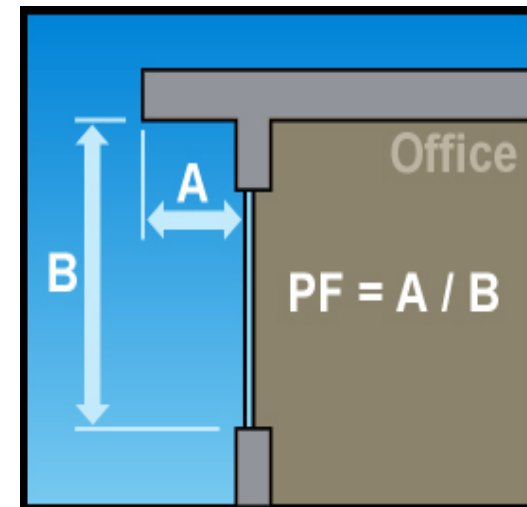
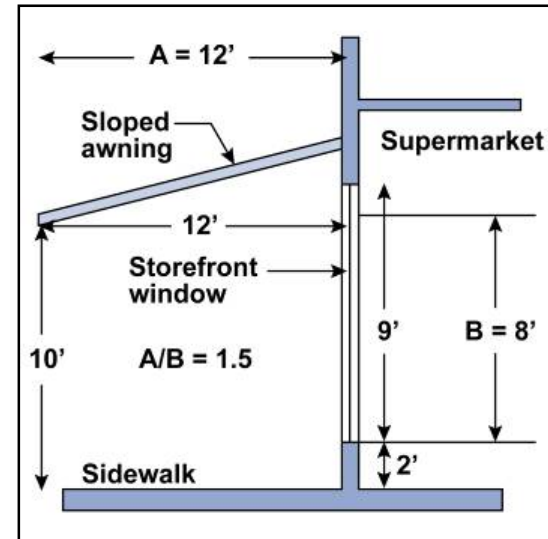

Using the Evaluation Checklists: Thermal Envelope Requirements

Opaque Door Requirements

- Permanently installed nameplate on all manufactured doors showing U-factor and Air Leakage Rate
- Opaque Doors must meet U-factor requirements of Tables 5.5- through 5.5-8

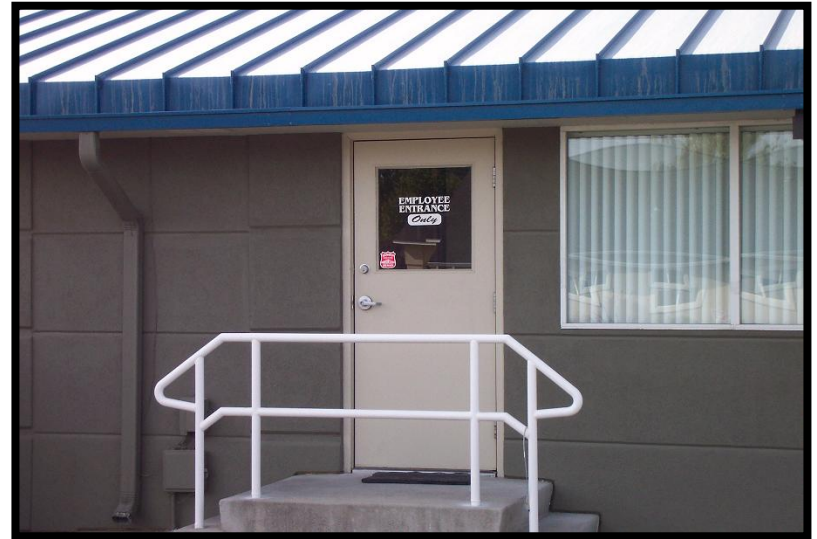
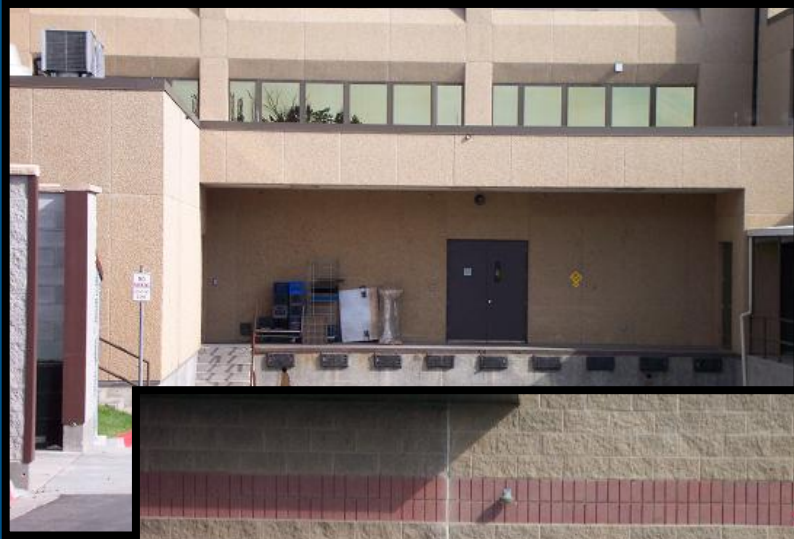

FI5
[5.8.2.3,
5.5.3.6]²

U-factor and air leakage of opaque doors associated with the building thermal envelope meets requirements.

Visible Light Transmittance

- A measure of the amount of visible light that passes through fenestration
- Affected by:
 - composition of the glass
 - coatings
 - internal shading devices
- Relationship between VLT and SHGC
 - Day-lighting without excessive solar gain– VLT at least 1.2 x SHGC



U.S. Department of Energy (2010)

Fenestration SHGC

- Vertical fenestration (*Section 5.5.4.4.1*)
 - SHGC values < Table value for appropriate total vertical fenestration area
- Skylights (*Section 5.5.4.4.2*)
 - SHGC values < Table value for appropriate total skylight area
- No SHGC requirements for semi-heated spaces
- No criteria for Visible Light Transmittance in Prescriptive Building Envelope Option, but there are minimum criteria in the Trade-Off Option (Details in Appendix C)
- Exceptions



U.S. Department of Energy (2010)

Section 5 – 5.6.1

Building Envelope Trade-Off Option “Rules”

Building must comply with Sections 5.1, 5.4, 5.7, and 5.8

Complies with trade-off option if envelope performance factor (EPF) of proposed design is less than or equal to that of budget building defined by rules in Appendix C

- *All building envelope components shown on drawings or installed in existing buildings to be included in proposed building design*
- *Fenestration and opaque envelope types and area used in simulation model to be consistent with design documents*
- *Don't need to separately describe any envelope assembly covering < 5% of total area of that assembly*
 - *as long as it's similar to an assembly being modeled*
 - *if not separately described, add the area of that assembly to an assembly with same orientation and thermal properties*

Section 5 – 5.6.1.2 Trade-Offs Limited to Building Permit

- *If building permit will apply to less than the whole building*
 - *Parameters relating to unmodified existing conditions or future building components to be identical for both proposed EPF and base EPF*
- *Future components meet prescriptive requirements of Section 5.5*



Section 5 – 5.7 Submittals

- General – AHJ can require compliance documentation and supplemental information per 4.2.2
- Space Conditioning Categories – if building has semiheated or unconditioned spaces and compliance is sought using semiheated criteria, spaces to be clearly indicated on floor plans
- Visible Transmittance – include test results for skylight glazing or diffusers (per 5.8.2.5)
- **Daylight Areas** – *documentation to identify daylight areas on floor plans, including*
 - *Primary sidelighted areas*
 - *Secondary sidelighted areas*
 - *Daylight area under skylights*
 - *Daylight areas under roof monitor*

Section 5 – 5.8: Product Information and Installation Requirements

- ✓ Labeling of Building Envelope Insulation (*Section 5.8.1.1*)
- ✓ Compliance with Manufacturers' Requirements (*Section 5.8.1.2*)
- ✓ Loose-Fill Insulation Limitation (*Section 5.8.1.3*)
- ✓ Baffles (*Section 5.8.1.4*)
- ✓ Substantial Contact (*Section 5.8.1.5*)
- ✓ Recessed Equipment (*Section 5.8.1.6*)
- ✓ Insulation Protection (*Section 5.8.1.7*)
- ✓ Location of Roof Insulation (*Section 5.8.1.8*)
- ✓ Extent of Insulation (*Section 5.8.1.9*)
- ✓ Joints in Rigid Insulation (*Section 5.8.1.10*)

Insulation - Substantial Contact (Section 5.8.1.5)

- Install insulation in a permanent manner in substantial contact with inside surface
- Flexible batt insulation in floor cavities
 - Supported in a permanent manner by supports no more than 24 in. on center (o.c.)

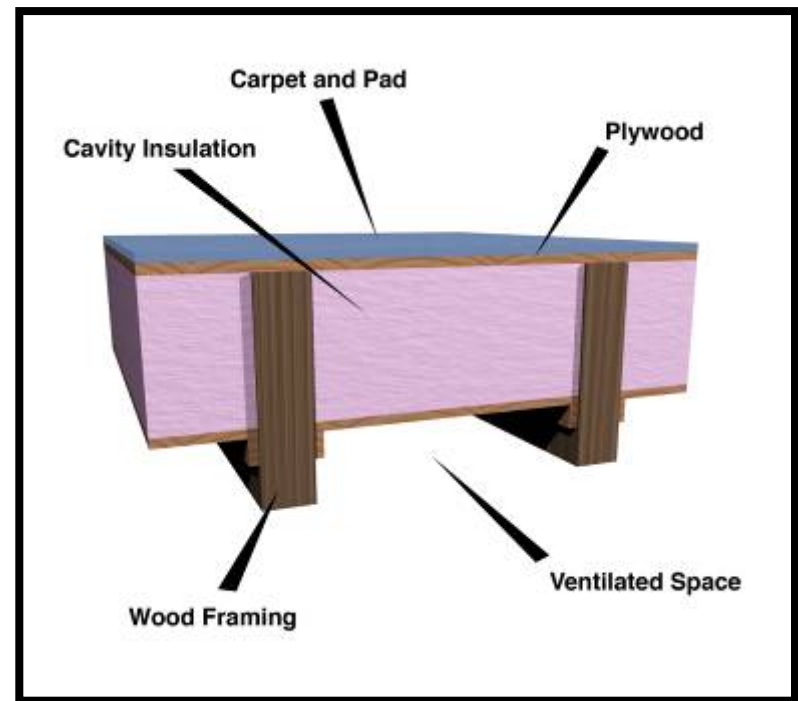

U.S. Department of Energy (2010)

Recessed Equipment (Section 5.8.1.6)

- Do not recess equipment to affect insulation thickness
 - Lighting fixtures
 - HVAC equipment (includes wall heaters, ducts, and plenums)
 - Other
- Except when
 - Total combined area affected (include necessary clearances) is < 1% of opaque area of the assembly, **OR**
 - Entire roof, wall, or floor is covered with insulation to the full depth required, **OR**
 - Effects of reduced insulation are included in area-weighted calculations

Section 5 – 5.8.1.7 -Insulation Protection

Insulation Protection

- Cover exterior insulation with protective material
 - Sunlight
 - Moisture
 - Landscaping operations
 - Equipment maintenance
 - Wind
- Access to attics and mechanical rooms without damaging or compressing insulation
- Insulation materials in ground contact to have a water absorption rate $\leq 0.3\%$ (ASTM C272)

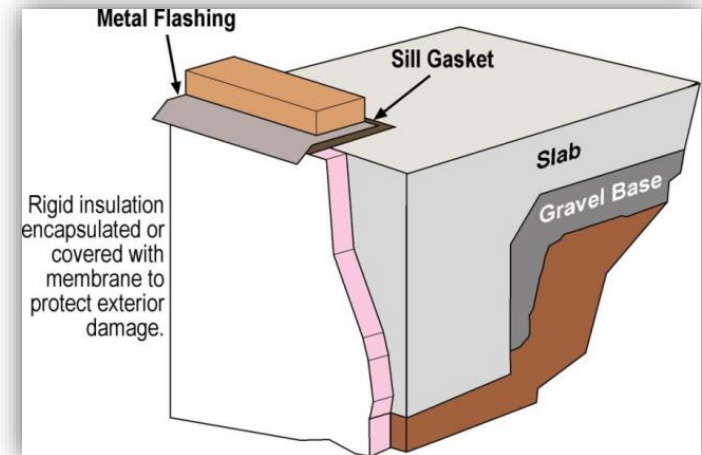

Example

Section 5 – 5.8.1.8 - Suspended Ceilings

Roof Insulation

- Not installed on a suspended ceiling with removable ceiling panels
- Non-compliant



Insulation Protection

Insulation Protection:

- Cover exterior insulation with protective material (*Section 5.8.1.7*)
 - Sunlight
 - Moisture
 - Landscaping operations
 - Equipment maintenance
 - Wind
- Access to attics and mechanical rooms without damaging or compressing insulation (*Section 5.8.1.7.1*)
- Insulation materials in ground contact to have a water absorption rate $\leq 0.3\%$ (ASTM C272) (*Section 5.8.1.7.3*)

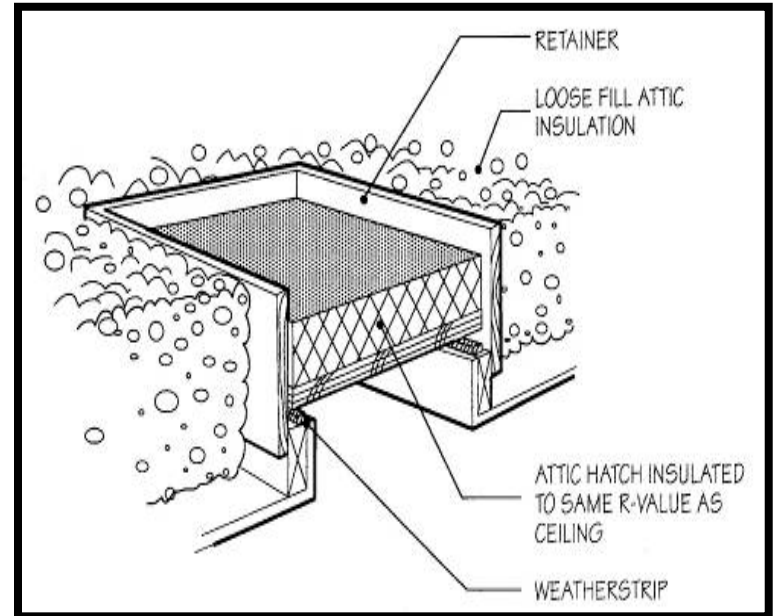

U.S. Department of Energy (2010)

Suspended Ceilings

Roof Insulation:

- Not installed on a suspended ceiling with removable ceiling panels (*Section 5.8.1.8*)



U.S. Department of Energy (2010)

Using the Evaluation Checklists: Insulation Compression



IN7
[5.8.1.6]²

Recessed equipment installed in building envelope assemblies does not compress the adjacent insulation.

Using the Evaluation Checklists

Foundation Vents & Insulation

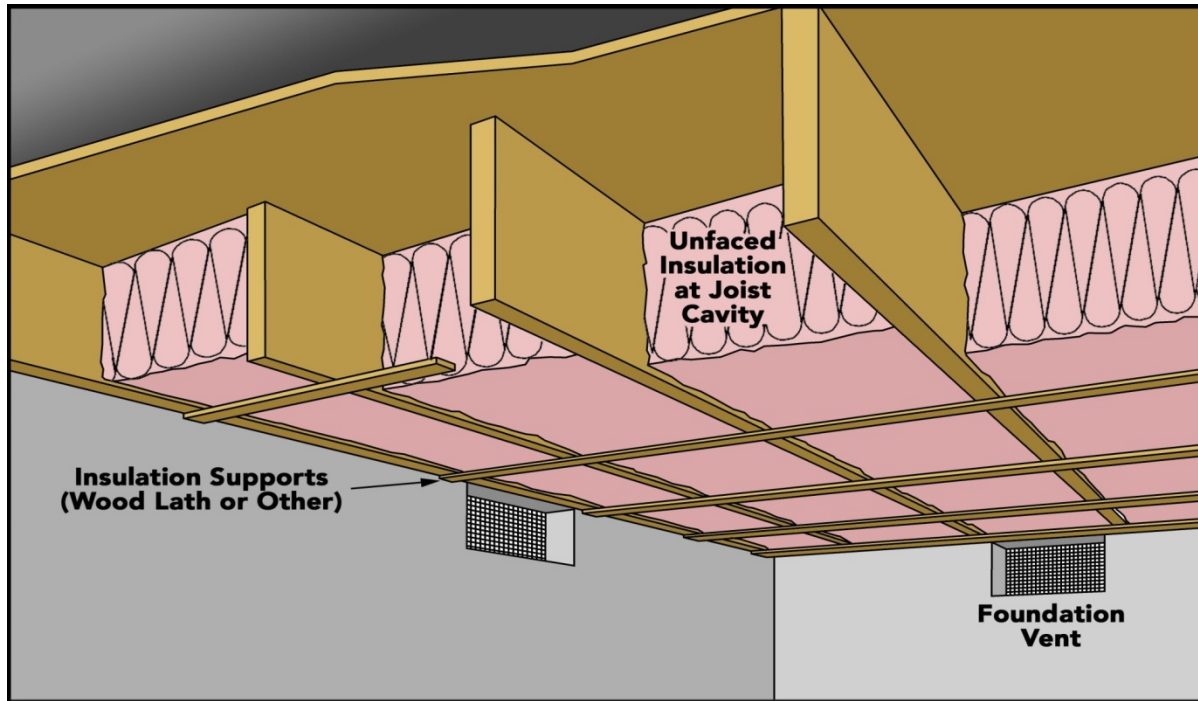

IN9

[5.8.1.7.1]²

Foundation vents do not interfere with insulation.

Using the Evaluation Checklists: Roof Insulation



IN15
[5.8.1.8]³

Roof Insulation not installed on suspended ceiling with removable panels.

Section 5- Building Envelope

Building Envelope Trade-Off Option (Section 5.6)

5.6.1.1 Modifies language addressing modeling of the envelop of a proposed design and the base building in the simulation model

5,6.1.2 Trade-Offs Limited to Building Permit- addresses how future building components shall be addressed in the simulation model.

Section 5- Building Envelope

Submittals (Section 5.7)

5.7.3 Visible Light Transmittance. Establishes that test results for skylight glazing be included in the contract documents submitted for a building permit.

5.7.4 Submittal Documentation of Daylight Areas- new section requires daylight areas to be shown on the floor plan

Section 5- Building Envelope

*Product Information and Installation Requirements
(Section 5.8)*

5.8.1.10 Joints in Rigid Insulation- requires joints to be staggered when two or more layers of rigid insulation are used.

Section 5- Building Envelope

5.8.2 Fenestration and Door Products

- *5.8.2.2 Fenestration and Door Products- all manufactured and site built fenestration products shall be labeled or a certificate from the product manufacturer and establishes an exception for doors with less than 25% glass.*
- *5.8.2.5 Visible Transmittance-establishes an exception and alternate procedure when not within scope of NFRC 200.*

Lighting (Section 9)

- General Application (*Section 9.1*)
 - Scope
 - Lighting Alterations
 - Installed Interior Lighting Power
 - Luminaire Wattage
- Compliance Path(s) (*Section 9.2*)
- Mandatory Provisions (*Section 9.4*)
 - Lighting control
 - Tandem wiring
 - Exit signs
 - Exterior building grounds lighting
 - Exterior building lighting power
- Building Area Method Compliance Path (*Section 9.5*)
- Alternative Compliance Path: Space-by-Space Method (*Section 9.6*)



U.S. Department of Energy (2010)

Section 9 - Lighting

- ✓ General Application (*Section 9.1*)
 - Scope
 - Lighting Alterations
 - Installed Lighting Power
 - *Interior and Exterior* Luminaire Wattage
- ✓ Compliance (*Section 9.2*)
- ✓ Mandatory Provisions (*Section 9.4*)
 - Lighting control
 - Exterior building lighting power
 - Functional testing
- ✓ Building Area Method Compliance Path (*Section 9.5*)
- ✓ Alternative Compliance Path: Space-by-Space Method (*Section 9.6*)



Section 9 - Lighting General Scope

- Interior spaces of buildings
- Exterior building features
- Exterior grounds lighting powered through building

Exceptions

- Emergency lighting
- Lighting required by life safety statute
- Lighting within dwelling units of buildings
- Decorative gas lighting



Section 9 – Lighting

ASHRAE 90.1 (2013) 17 pages + 240% from
ASHRAE 90.1 (2007) 7 pages

General (Section 9.1)

- *9.1.2 Lighting Alterations-added alteration language. Michigan amends the exception threshold to 50% of connected lighting load for when requirements do not apply.*

Basic Lighting Requirements

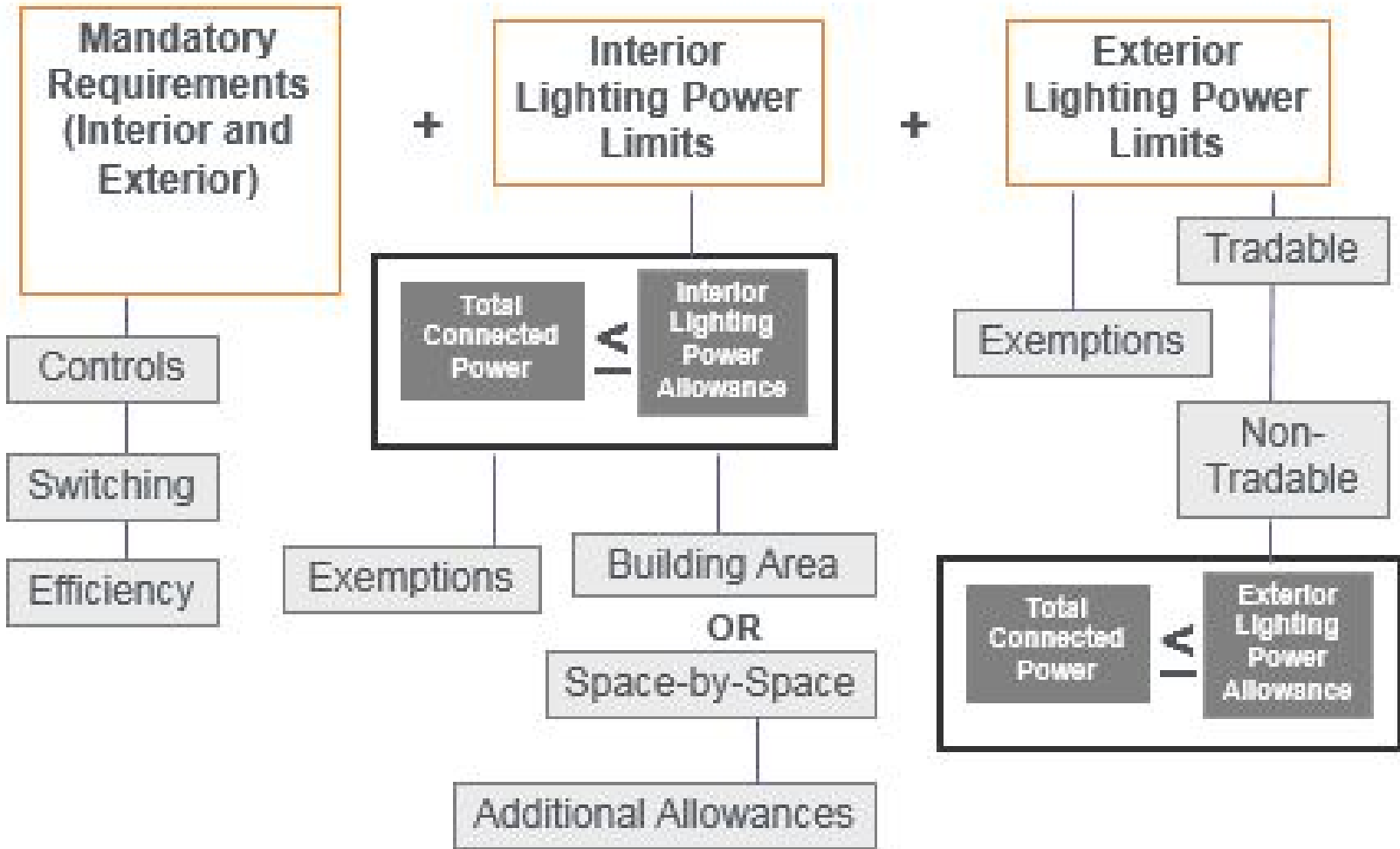

Source: slide modified from www.energycodes.gov ANSI/ASHRAE Standard 90.1 2013 Power and Lighting - VISITED SEPT. 5, 2017

Section 9 – Lighting

Compliance (Section 9.2) –

- *9.2.2.3 Interior Lighting Power-this section requires using the Building Area Method or Space by Space Method.*
- *Exceptions for certain lighting from being included in the calculation under this section are modified from the ASHRAE 90.1 (2007)*
- *Two new exceptions for mirror lighting and certain parking garages transition lighting are added.*

Section 9 – 9.1.3 Installed Lighting Power Calculation Requirements

These requirements apply to both interior and exterior:

Installed Lighting Power shall include all power used by the luminaires, including lamps, ballasts, transformers, and controls

- **Exception**: where two independent lighting systems exist in the same space or area and are controlled to prevent simultaneous operation, only the system with the highest total wattage must be included

Luminaire Wattage for various systems shall be determined in accordance with details in Section 9.1.4

Exceptions-Interior Lighting Power Calculation Exemptions

Lighting that does not have to be included in the installed lighting power calculation:

- Theatrical, stage, film, and video production
- Medical and dental procedures
- Exhibit displays for museums, monuments, and galleries
- Integral to equipment or instrumentation installed by manufacturer
- Integral to both open and glass-enclosed refrigerator and freezer cases
- Retail display windows, provided the display is enclosed by ceiling-height partitions
- Food warming and food preparation equipment
- Interior spaces specifically designated as registered interior historic landmarks
- Integral part of advertising or directional signage
- Exit signs
- Sale or lighting educational demonstration systems
- Lighting for television broadcasting in sporting activity areas
- Casino gaming areas
- Furniture-mounted supplemental task lighting controlled by automatic shutoff and complying with 9.4.1.4(d)
- For use in areas specifically designed for life support of nonhuman life forms
- Mirror lighting in dressing rooms and accent lighting in religious pulpit and choir areas
- Parking garage transition lighting

Section 9 Building Area Method

Can be used for entire building or separate building type occupancies

Advantages

- ✓ Fewer calculations

Limitations

- ✓ Limited building area type selection - use reasonably equivalent type
- ✓ Insensitive to specific space functions and room configurations
- ✓ Generally more restrictive than space-by-space method

Calculation Process

- 1) Determine gross lighted area for each building type area using:
 - Exterior faces of exterior walls
 - Centerline of interior walls
- 2) Calculate the area power allowance by multiplying the gross lighted area by the applicable building type allowance from Table 9.5.1
- 3) Sum all the allowances (if more than one building type area)

Section 9 – Table 9.5.1 Building Types

Part of Table 9.5.1 shown below.

Complete table in the Standard has 32 different building types

Building Type	Lighting Power Density (W/ft ²)
Automotive Facility	0.80
Convention Center	1.01
Court House	1.01
Dining: Bar Lounge/Leisure	1.01
Dining: Cafeteria/Fast Food	1.01
Dining: Family	1.01
Dormitory	0.57
Exercise Center	0.84

Section 9 – 9.6.1-Space-by-Space Method

Applies to any building configuration by calculating allowances for individual spaces

Advantages

- ✓ More flexible than building area method
- ✓ More accurately accounts for actual room lighting power needs
- ✓ Provides additional allowances for:
 - Difficult room configurations
 - Decorative and retail needs
 - Use of advanced controls not already required in the standard

Limitations

- ✓ More calculations needed (individual spaces)

Calculation Process

- 1) Determine the gross lighted area of each space type
 - include balconies and mezzanines
 - Use centerline of walls between spaces
- 2) Calculate the space power allowance by multiplying the space type area by the applicable allowance from Table 9.6.1
- 3) Sum all the allowances

Section 9 – Table 9.6.1 Space-by-Space Allowances

Small part of Table 9.6.1 shown below
Approximately 100 different space types included in the Standard

TABLE 9.6.1 Lighting Power Density Allowances Using the Space-by-Space Method and Minimum Control Requirements Using Either Method

The control functions below shall be implemented in accordance with the descriptions found in the referenced paragraphs within Section 9.4.1.1. For each space type:

- (1) All REQs shall be implemented.
- (2) At least one ADD1 (when present) shall be implemented.
- (3) At least one ADD2 (when present) shall be implemented.

Informative Note: This table is divided into two sections; this first section covers space types that can be commonly found in multiple building types. The second part of this table covers space types that are typically found in a single building type.

Local Control (See Section 9.4.1.1[a])	Restricted to Manual ON (See Section 9.4.1.1[b])	Restricted to Partial Automatic ON (See Section 9.4.1.1[c])	Bilevel Lighting Control (See Section 9.4.1.1[d])	Automatic Daylight Responsive Controls for Sidelighting (See Section 9.4.1.1[e])	Automatic Daylight Responsive Controls for Toplighting (See Section 9.4.1.1[f])	Automatic Partial OFF (See Section 9.4.1.1[g]) [Full Off complies]	Automatic Full OFF (See Section 9.4.1.1[h])	Scheduled Shutoff (See Section 9.4.1.1[i])
-------------------------------------------	-----------------------------------------------------	----------------------------------------------------------------	------------------------------------------------------	-------------------------------------------------------------------------------------	------------------------------------------------------------------------------------	--------------------------------------------------------------------------	------------------------------------------------	-----------------------------------------------

Common Space Types ¹	LPD, W/ft ²	RCR Threshold	a	b	c	d	e	f	g	h	i
Atrium											
... that is <20 ft in height	0.03/ft total height	NA	REQ	ADD1	ADD1	—	REQ	REQ	—	ADD2	ADD2
... that is ≥20 ft and ≤40 ft in height	0.03/ft total height	NA	REQ	ADD1	ADD1	REQ	REQ	REQ	—	ADD2	ADD2
... that is >40 ft in height	0.40 + 0.02/ft total height	NA	REQ	ADD1	ADD1	REQ	REQ	REQ	—	ADD2	ADD2
Audience Seating Area											
... in an auditorium	0.63	6	REQ	ADD1	ADD1	REQ	REQ	REQ	—	ADD2	ADD2
... in a convention center	0.82	4	REQ	ADD1	ADD1	REQ	REQ	REQ	—	ADD2	ADD2

Room Geometry Adjustment – 9.6.4

Room Cavity Ratio Adjustment for relief in unusual space configurations

- Used only when applying the space by space method
- Calculate the *Room Cavity Ratio* (RCR) for the empty room:
$$\text{RCR} = \frac{2.5 \times \text{Room Cavity Height} \times \text{room perimeter}}{\text{room area}}$$

(Room Cavity Height = Luminaire mounting height – Workplane height)

- If RCR is greater than the RCR threshold for that space type from Table 9.6.1, a 20% increase is allowed
- For corridor/transition spaces, a 20% adjustment is allowed when less than 8 feet wide, regardless of the RCR

Room Geometry Adjustment (1 of 2)

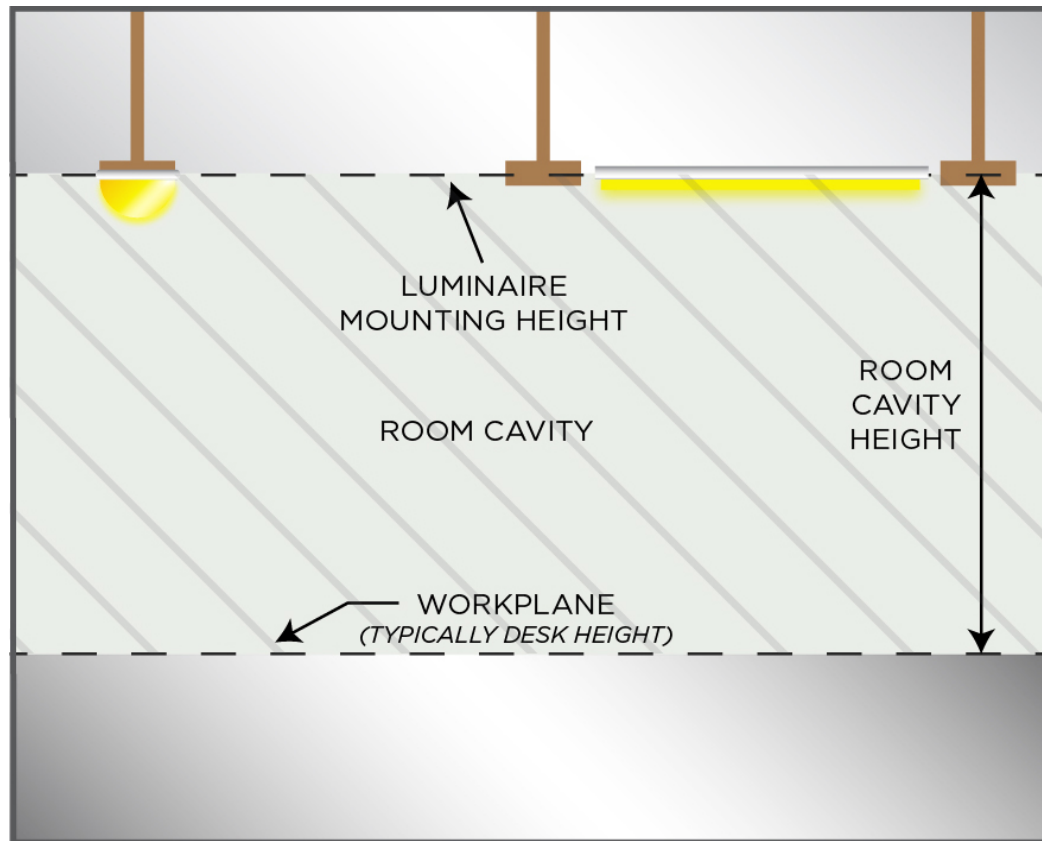

Room Geometry Adjustment (2 of 2)

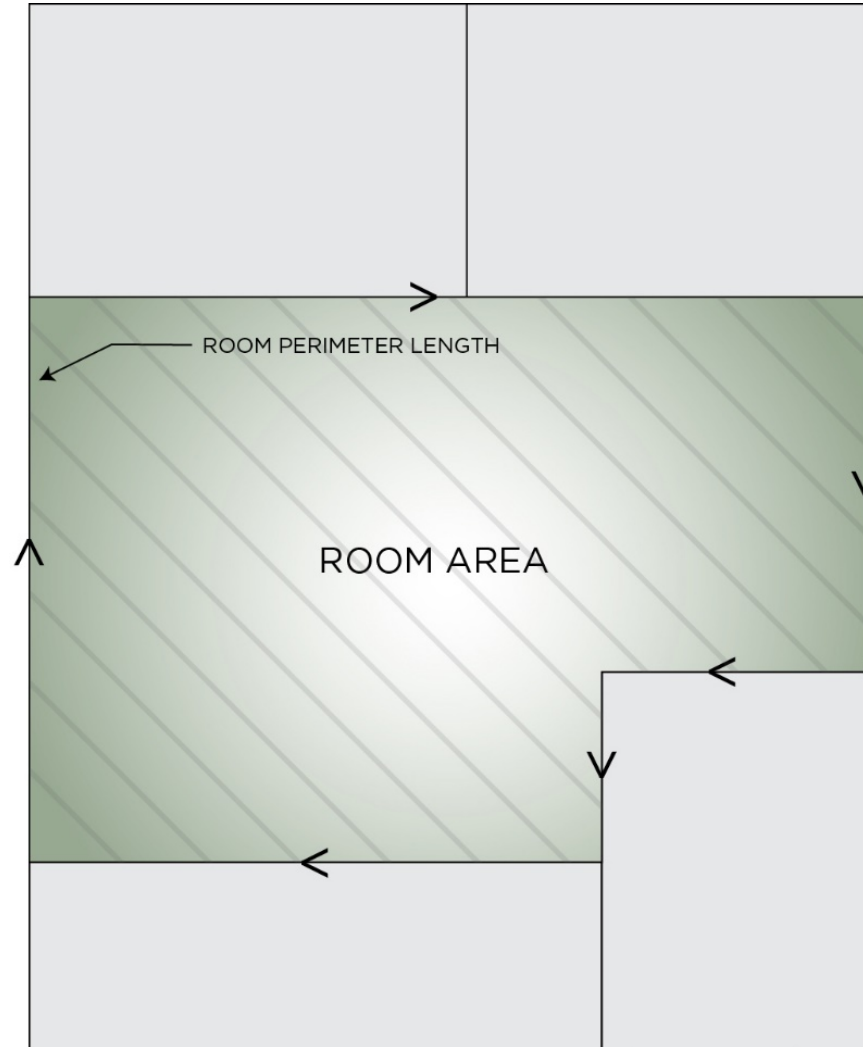

Section 9 – 9.6.2 – 9.6.3

Additional Interior Lighting Power

Decorative and Retail display highlighting

An increase in the lighting power allowance is allowed for specific decorative and retail applications when using the space-by-space method.

Must be automatically controlled, separately from the general lighting, to be turned off during non-business hours.

The additional allowances can only be used for the additional lighting equipment – and not general lighting

- ✓ Decorative luminaires in addition to the general lighting = 1.0 W/ft²
- ✓ Retail display lighting = varies by retail type

Advanced Controls

An increase in the allowance is also allowed for the use of specified advanced controls that are installed in addition to those already required



Section 9 – 9.6.3 Advanced Controls Incentive

If all mandatory control requirements are met for a space AND advanced controls are installed in that space, THEN additional limited lighting power is allowed:

- Additional power can be used anywhere in the building
- Additional Interior Lighting Power Allowance is calculated as

Lighting Power Under Control x Control Factor

Additional Control Method (in Addition to Mandatory Requirements).	Space Type				
	Open Office	Private Office	Conference Room, Meeting Room, Classroom (Lecture/ Training)	Retail Sales Area	Lobby, Atrium, Dining Area, Corridors/ Stairways, Gym/ Pool, Mall Concourse, Parking Garage
Manual, continuous dimming control or Programmable multi-level dimming control	0.05	0.05	0.10	0.10	0
Programmable multi-level dimming control using programmable time scheduling	0.05	0.05	0.10	0.10	0.10

(Partial) Table 9.6.3 Control Factors Used in Calculating Additional Interior Lighting Power Allowance

Section 9 – Lighting

Simplified Building (Section 9.3) –not used

Mandatory Provisions (Section 9.4)

- *9.4.1 Lighting Controls*
- *9.4.1.1 Interior Lighting Controls-this new section requires a number of lighting controls as indicated in Table 9.6.1.*

–see next slide for continuation

Section 9 – Lighting

- *9.4.1.1 Interior Lighting Controls (continued)*

Nine different lighting controls measures are defined.

Table 9.6 is used to determine which lighting controls are required for various space types.

All measures marked as REQ are required.

Measures marked as ADD 1 or ADD 2 each require a selection of at least one measure so marked.

Using the Evaluation Checklists

- Lighting controls required for each area enclosed by ceiling height partitions
- Switch locations
 - In view of lights
 - “On” or “off” indication from remote location

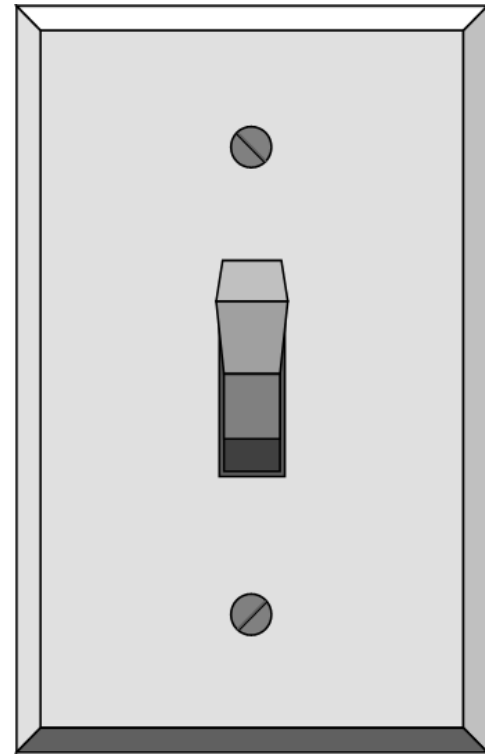

EL8

[9.4.1.2]²

Independent lighting control installed per approved lighting plans and all manual control readily accessible and visible to occupants.

Section 9.4.1.1 Interior Lighting Controls

For each space type, apply the lighting control functions listed.

- If using the Space-by-Space method for LPD requirements, use same space type for control requirements. For space types not listed, use a reasonable equivalent
- “REQ” = mandatory
- “ADD1” = at least one of these must be implemented
- “ADD2” = at least one of these must be implemented

TABLE 9.6.1 Lighting Power Density Allowances Using the Space-by-Space Method and Minimum Control Requirements Using Either Method

The control functions below shall be implemented in accordance with the descriptions found in the referenced paragraphs within Section 9.4.1.1. For each space type:

(1) All REQs shall be implemented.

(2) At least one ADD1 (when present) shall be implemented.

(3) At least one ADD2 (when present) shall be implemented.

Informative Note: This table is divided into two sections; this first section covers space types that can be commonly found in multiple building types. The second part of this table covers space types that are typically found in a single building type.

Common Space Types ¹	LPD, W/ft ²	RCR Threshold	Local Control (See Section 9.4.1.1[a])	Restricted to Manual ON (See Section 9.4.1.1[b])	Restricted to Partial Automatic ON (See Section 9.4.1.1[c])	Bilevel Lighting Control (See Section 9.4.1.1[d])	Automatic Daylight Responsive Controls for Sidelighting (See Section 9.4.1.1[e])	Automatic Daylight Responsive Controls for Toplighting (See Section 9.4.1.1[f])	Automatic Partial OFF (See Section 9.4.1.1[g] [Full Off complies])	Automatic Full OFF (See Section 9.4.1.1[h])	Scheduled Shutoff (See Section 9.4.1.1[i])
			a	b	c	d	e	f	g	h	i
Atrium											
... that is <20 ft in height	0.03/ft total height	NA	REQ	ADD1	ADD1	—	REQ	REQ	—	ADD2	ADD2
... that is ≥20 ft and ≤40 ft in height	0.03/ft total height	NA	REQ	ADD1	ADD1	REQ	REQ	REQ	—	ADD2	ADD2
... that is >40 ft in height	0.40 + 0.02/ft total height	NA	REQ	ADD1	ADD1	REQ	REQ	REQ	—	ADD2	ADD2
Audience Seating Area											
... in an auditorium	0.63	6	REQ	ADD1	ADD1	REQ	REQ	REQ	—	ADD2	ADD2
... in a convention center	0.82	4	REQ	ADD1	ADD1	REQ	REQ	REQ	—	ADD2	ADD2

Section 9.4.1.1 Control Functions

- Local control
- Restricted to manual ON
- Restricted to partial automatic ON
- Bilevel lighting control
- Automatic daylight responsive controls for sidelighting
- Automatic daylight responsive controls for toplighting
- Automatic partial OFF (full OFF complies)
- Automatic full OFF
- Scheduled shutoff

Section 9 – 9.4.1.1 (a) Local Control

At least one control that controls all the lighting in the space

- In spaces $\leq 10,000$ ft², each control serves 2,500 ft² maximum and in spaces $> 10,000$ ft², serves 10,000 ft² maximum

Section 9 – 9.4.1.4

Daylight Zone Definition – Primary Sidelighted Area

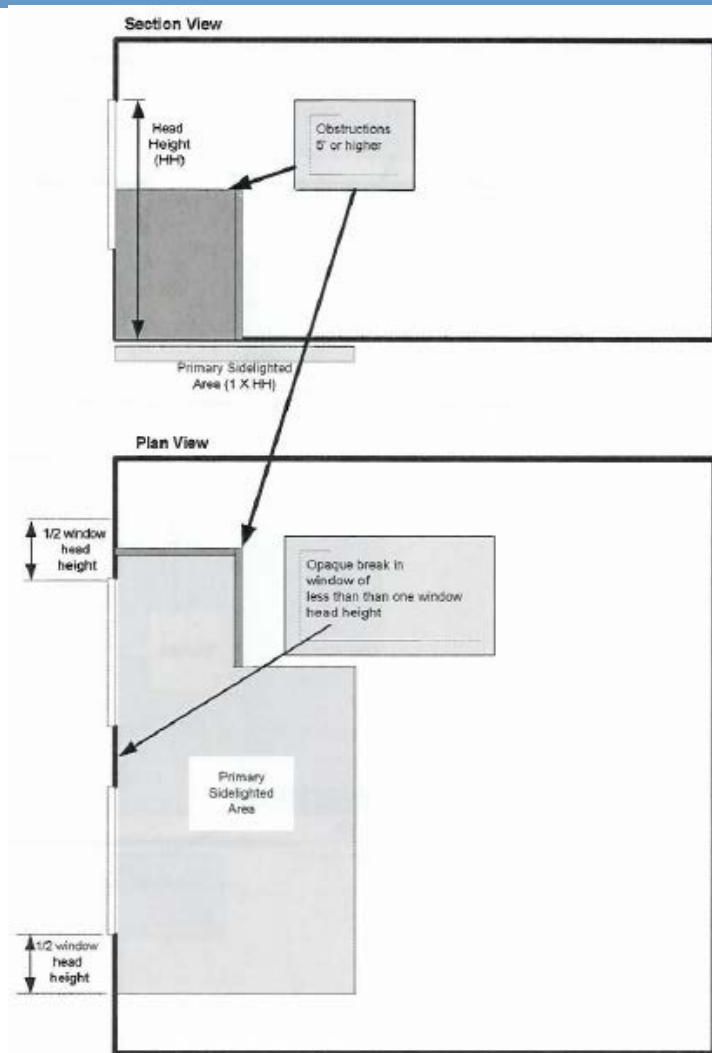

© 2013, ASHRAE, ANSI/ASHRAE/IES Standard 90.1-2013, Figure 3.2-3

Section 9 – 9.4.1.4 Daylight Zone Definition – Under Rooftop Monitors

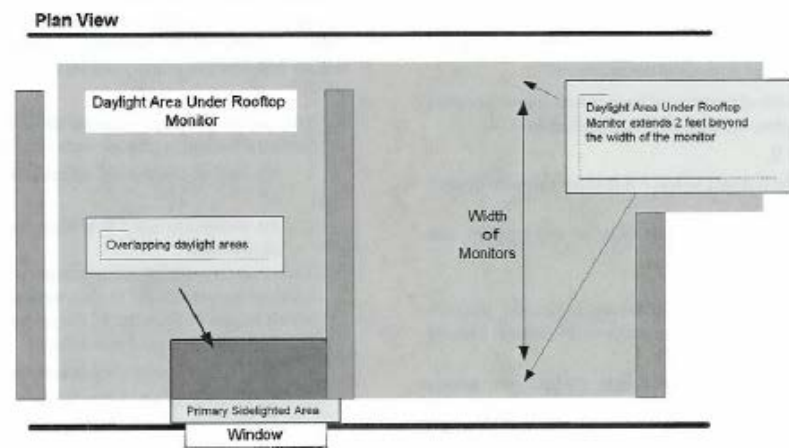
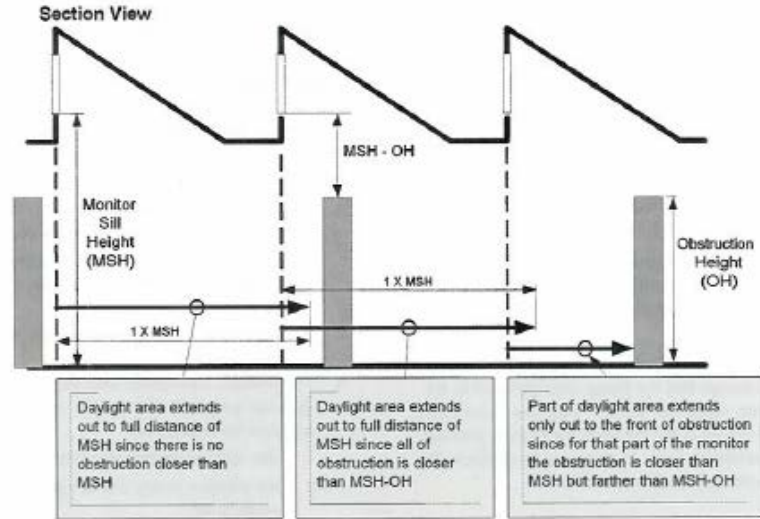

© 2013, ASHRAE, ANSI/ASHRAE/IES Standard 90.1-2013, Figure 3.2-1

Section 9 – Lighting

9.4.1.2 Parking Garage Lighting Controls-new section requires:

- *automatic lighting shutoff*
- *automatically reducing power by 30% for periods of inactivity in a lighting zones of 20 minutes.*
- *Lighting zones shall be a maximum of 3600 sf.*

Section 9 – 9.4.1.2 -Parking Garage Lighting Control

- Automatic lighting shutoff per 9.4.1.1 (i)
- Must reduce lighting power by minimum of 30% when no activity is detected for **20** minutes within a lighting zone $\leq 3,600 \text{ ft}^2$
- Automatically reduce power in response to daylight for luminaires within 20 ft of any perimeter wall that has
 - a net opening to wall ratio of $\geq 40\%$ and
 - no exterior obstructions within 20 ft

Exception

- Daylight transition zones and ramps without parking are exempt from 30% reduction and daylight control

Section 9 – 9.4.1.2 Parking Garage Lighting Control

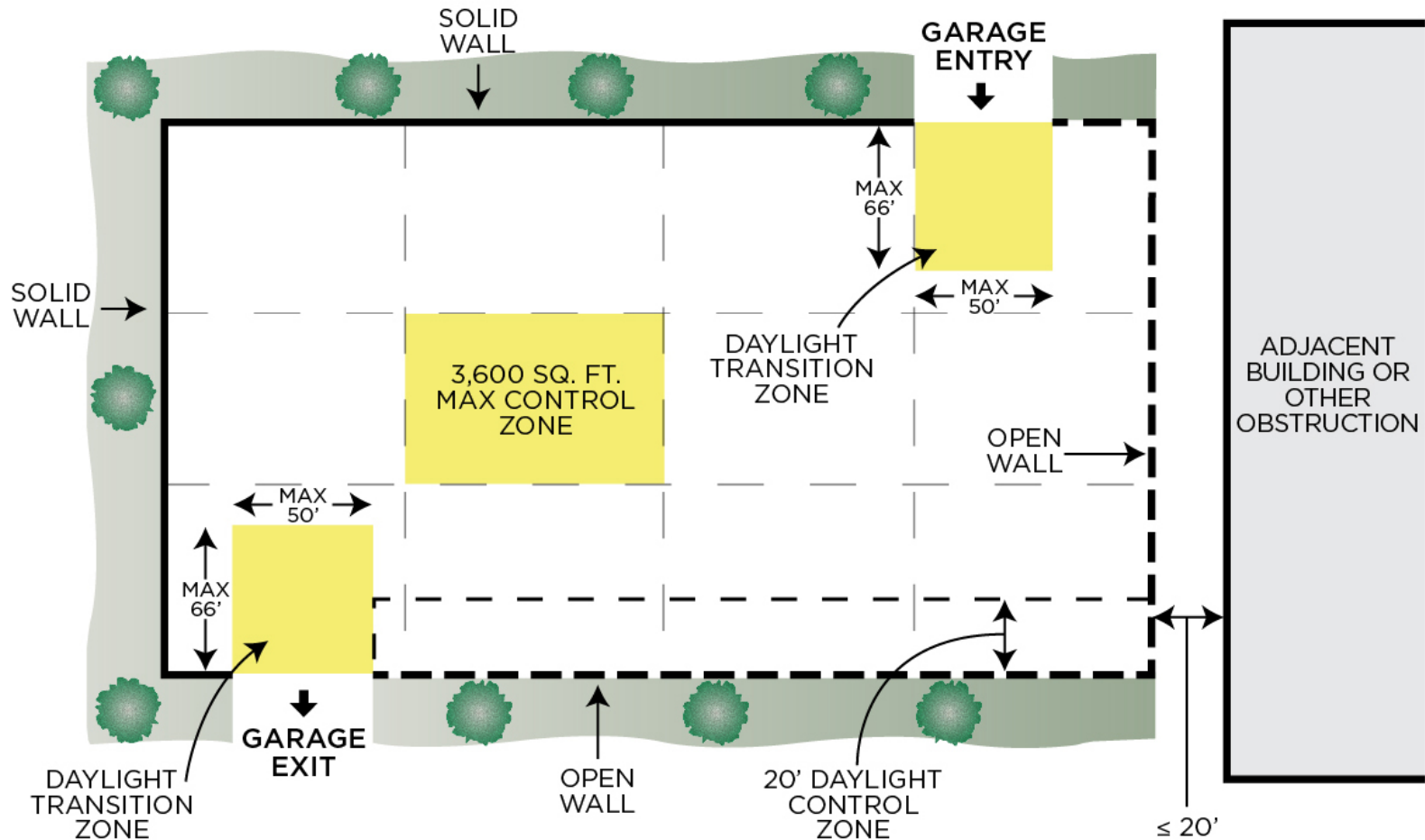

Section 9 – Lighting

9.4.1.3 Special Applications-sets requirements for certain display lighting, non visual lighting for plant growth or food warming and lighting equipment for sale to be separately controlled.

Establishes that lighting and switched receptacles in guestrooms and suites in hotels, motels and boarding houses shall be automatically controlled.

Bathrooms shall have separate control device that shuts off lighting after 20 minutes.

Section 9 – 9.4.1.3 - Control of Special Applications

Special applications separately controlled from general lighting

- Display or accent lighting
- Case lighting
- Nonvisual lighting
- Demonstration lighting



Section 9 – 9.4.1.3 Control of Special Applications

- Guestroom lighting *and switched receptacles to be turned off within 20 minutes of occupants leaving the space*
 - **Exception:** where captive key systems used
- Bathrooms controlled to automatically turn off lighting within **30** minutes of occupants leaving space
 - **Exception:** night lighting not > 5W
- Supplemental task lighting controlled by
 - Controller integral to the luminaires OR
 - Wall-mounted controller-readily accessible and located so occupant can see controlled lighting



Section 9 – Lighting

9.4.1.4 Exterior Lighting Control-sets requirements for exterior lighting.

It establishes early and late hours of operation and for periods with no activity.

It also establishes that switches retain their programmed settings during periods of lost power.

Using the Evaluation Checklists Installed Lamps and Fixtures



FI3
[9.1.3]¹

Installed lamps and fixtures are consistent with what is shown on the approved lighting plans.

Using the Evaluation Checklists

Exterior Ground Lighting Controls

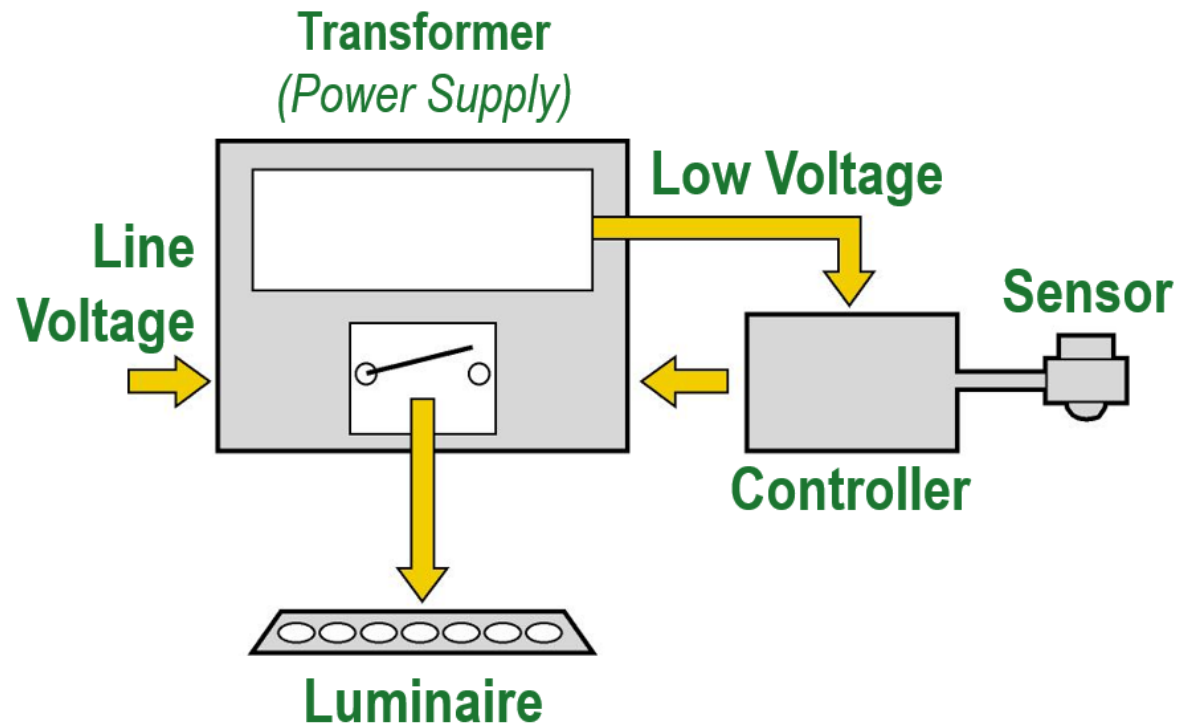

EL3
[9.4.4]¹

Exterior ground lighting over 100 W provides >60 lm/W unless on motion sensor or fixture is exempt from scope of code or from external LPD.

Section 9 – 9.4.1.4 Mandatory Exterior Lighting Control

- Lighting must turn off when there is sufficient daylight
- Building façade and landscape lighting must be shut off between
 - midnight or business closing (whichever is later) and
 - 6am or business opening (whichever comes first)
 - OR
 - times established by AHJ
- Power for other lighting *and lighting for signage* to be automatically reduced by at least 30%
 - From midnight or within 1 hour of end of business operations (whichever is later) and until 6am or business opening (whichever is earlier) OR
 - During any period when no activity has been detected for a time no longer than 15 minutes



Exceptions

- Covered vehicle entrances
 - Exits from buildings or parking structures
- (where required for safety, security, or eye adaptation)*
- *Lighting integral to signage and installed by manufacturer*

Section 9 – Lighting

9.4.2 Exterior Building Lighting Power-this section is modified to add determination of exterior lighting “Zones” from Table 9.4.2.

Exterior lighting power for various tradeable and non-tradeable surfaces is determined from Table 9.4.2-2 Individual Lighting Power Allowances for Building Exteriors.

The section also identifies numerous exceptions for lighting which is exempt from the densities in Table 9.4.2-2

Section 9.4.2 Exterior Lighting Power

Exterior Building Lighting Power must meet prescribed power limits.

- The total exterior lighting power allowance is the sum of the base site allowance plus individual lighting power densities (LPD) for the applicable “lighting power zone”
- Trade-offs are allowed only among “Tradable Surfaces” applications
- Some exemptions apply



Section 9.4.5 - Exterior Lighting Power Zones

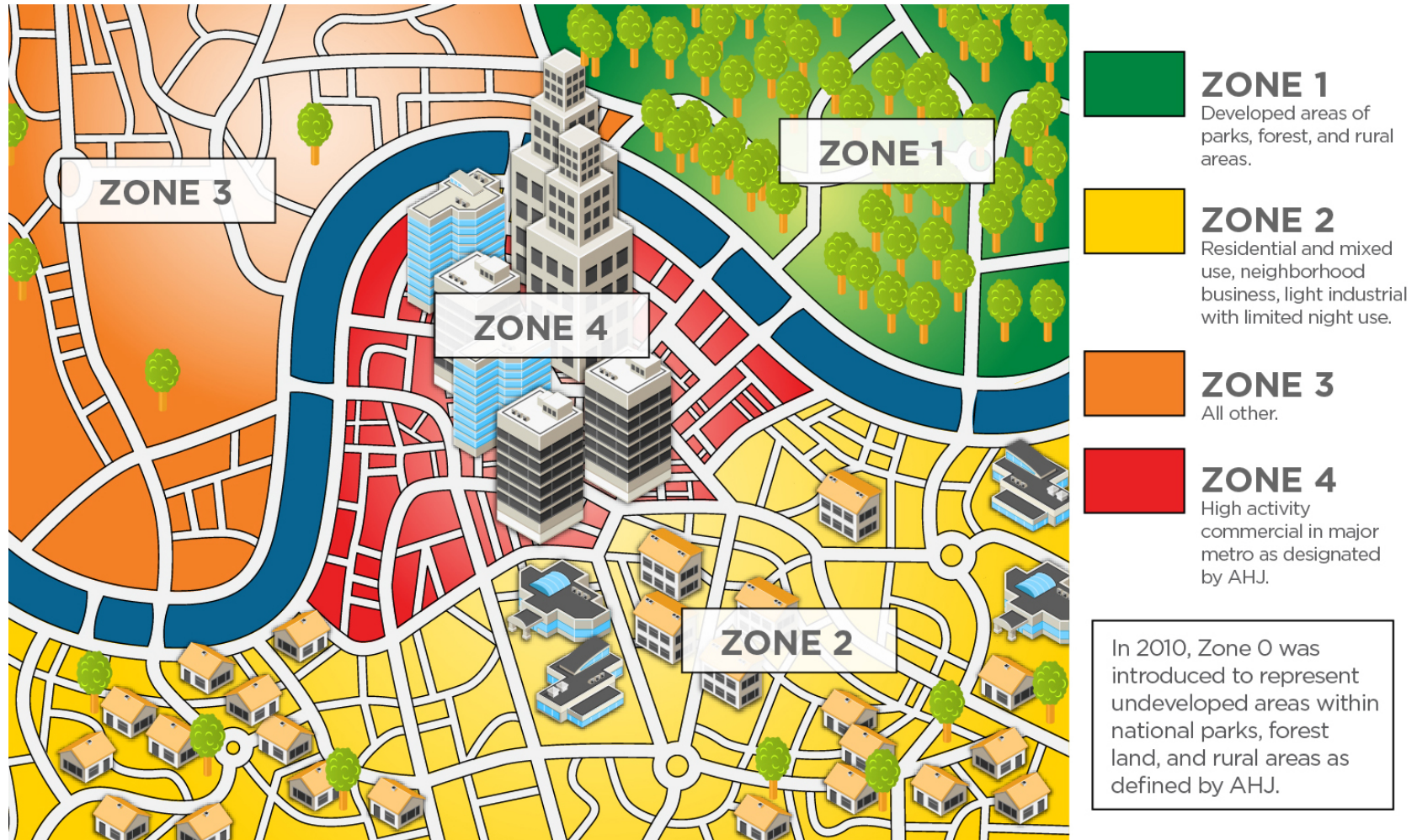

Section 9 Tradable Exterior LPDs (1 of 2)

Exterior applications are divided into 2 categories:

Tradable: *allowed wattage may be traded among these applications*

Non-Tradable: *allowed wattage cannot be traded between surfaces or with other exterior lighting*

Section 9 Tradable Exterior LPDs (2 of 2)

TABLE 9.4.3B Individual Lighting Power Allowances for Building Exteriors

	Zone 0	Zone 1	Zone 2	Zone 3	Zone 4
Base Site Allowance (base allowance may be used in tradable or non-tradable surfaces)					
No Base Site in Zone 0		500 W	600 W	750 W	1300 W
Tradable Surfaces (LPDs for uncovered parking areas, building grounds, building entrances and exits, canopies and overhangs, and outdoor sales areas may be traded.)					
Uncovered parking areas					
Parking areas and drives	No allowance	0.04 W/ft ²	0.06 W/ft ²	0.10 W/ft ²	0.13 W/ft ²
Building grounds					
Walkways less than 10 ft wide	No allowance	0.7 W/linear foot	0.7 W/linear foot	0.8 W/linear foot	1.0 W/linear foot
Walkways 10 ft wide or greater	No allowance	0.14 W/ft ²	0.14 W/ft ²	0.16 W/ft ²	0.2 W/ft ²
Plaza areas	No allowance	0.14 W/ft ²	0.14 W/ft ²	0.16 W/ft ²	0.2 W/ft ²
Special feature areas	No allowance	0.14 W/ft ²	0.14 W/ft ²	0.16 W/ft ²	0.2 W/ft ²
Stairways	No allowance	0.75 W/ft ²	1.0 W/ft ²	1.0 W/ft ²	1.0 W/ft ²
Pedestrian tunnels	No allowance	0.15 W/ft ²	0.15 W/ft ²	0.2 W/ft ²	0.3 W/ft ²
Landscaping	No allowance	0.04 W/ft ²	0.05 W/ft ²	0.05 W/ft ²	0.05 W/ft ²
Building entrances and exits					

Section 9 – 9.4.3

Exterior Lighting Power Exemptions

The following are exempt when equipped with separate controls:

- lighting that is integral to signage *and installed by its manufacturer*;
- lighting for athletic playing areas;
- lighting for industrial production, material handling, transportation sites, and associated storage areas;
- theme elements in theme/amusement parks;
- lighting used to highlight features of public monuments and registered historic landmark structures or buildings;
- lighting for water features;
- specialized signal, directional, and marker lighting associated with transportation;
- lighting that is integral to equipment or instrumentation and is installed by its manufacturer;
- lighting for theatrical purposes, including performance, stage, film, and video production;
- temporary lighting;
- lighting for hazardous locations;
- Lighting for swimming pools;
- searchlights.

Section 9 – Lighting

9.4.3 Functional Testing-new section requires control systems be tested and calibrated with control hardware and software.

Requirements for testing Occupant Sensors, Automatic Time Switches and Daylight Controls

Testing to be conducted by someone other than the design professional or constructor for the project

Documentation required certifying the results.

Section 9 – Lighting

Building Area Compliance Path (Section 9.5) –no significant changes

*Alternative Compliance Path- Space by Space Method
(Section 9.6)*

9.6.3 Additional Interior Lighting Power Using Non-mandatory controls-this section establishes that when non-mandatory controls are added, additional lighting power is allowed.

Table 9.6.3 is used to determine the increase.

Section 9 – Lighting

Building Area Compliance Path (Section 9.5) –no significant changes

*Alternative Compliance Path- Space by Space Method
(Section 9.6)*

9.6.4 Room Geometry Adjustment-this new section allows for increase in lighting power density as a function of the “Room Cavity Ratio” which is calculated by multiplying the Room Cavity Height by the Room Perimeter and dividing by the Room Area.

Section 9 – Lighting

Submittals (Section 9.7)

9.7 Submittals

- *Sections 9.7.1 General, 9.7.2 Completion Requirements, 9.7.2.1 Drawings, 9.7.2.2 Manuals and 9.7.2.3 Daylight Documentation together establish the requirements and time frames for submitting documents. Record drawings and manuals must be provided to the owner within 90 days.*

Section 9 – Lighting

Product Information and Installation Requirements
(Section 9.8) (Not used)

Tables 9.6.1 Lighting Power Density Using Space by Space Method is substantially changed to include:

- *Lower LPD*
- *The lighting control measures*
- *RCR (Room Cavity Ratio)*

Table 9.5.1 Lighting Power Densities Using the Building Area Method has lower LPD's for various building types.

Using the Evaluation Checklists

Additional Interior Lighting Power

- Space-by-space increases
 - Specific lighting function
 - Only if specific lighting is installed
 - Only for specified luminaires
 - Shall not be used for any other purpose or space



EL4
[9.6.2] ¹

Additional interior lighting power allowed for special functions per the approved lighting plans and is automatically controlled and separated from general lighting.

ASHRAE 90.1 (2013) Significant Changes – Section 6 (1 of 31)

Section 6 - Heating, Ventilating, and Air Conditioning

ASHRAE 90.1 (2013) 41
pages + 57%

ASHRAE 90.1 (2007) 26
pages

General (Section 6.1)- no
significant changes



Section 6 – 6.1.1.3 HVAC Alterations Scope

- **Equipment**
 - New equipment shall meet the minimum efficiency requirements
- **Cooling systems**
 - New cooling systems installed to serve previously uncooled spaces shall comply with this section
 - Alterations to existing cooling systems shall not decrease economizer capacity (unless economizer tradeoff is used)
- **Ductwork**
 - New and replacement ductwork shall comply with applicable requirements
- **Piping**
 - New and replacement piping shall comply with applicable requirements

Section 6 - Heating, Ventilating, and Air Conditioning

Compliance Paths (Section 6.2)

6.2.1 Compliance - adds meeting the Mandatory provisions of 6.4 along with 6.6 Alternative Compliance Path as an additional way to comply

Section 6 - Heating, Ventilating, and Air Conditioning

Simplified Approach Option for HVAC Systems (Section 6.3)

This approach is used for smaller buildings up to 25,000 sf and two stories or less. Requires compliances with all 18 conditions. The changes add six new conditions for using the simplified method including:

- b. meeting variable air flow requirements*
- d. system must have an economizer*
- f. meet exhaust air recovery requirements*
- n. requirements for intakes and exhaust systems*
- q. comply with demand control ventilation requirements*
- r. comply with “door switch” requirements*

Section 6 – 6.3 Simplified Approach Option

The simplified approach is an optional path for compliance when the following are met:

- Buildings with 1 or 2 stories
- Buildings with gross floor area < 25,000 ft²
- System serving single HVAC zone
- Unitary packaged or split air conditioners (air-cooled or evaporatively cooled)



Section 6 – 6.3 Simplified Approach Criteria

- a. Single HVAC zone
- b. Single zone VAV controls (*6.5.3.2.1*)
- c. Cooling equipment efficiency (6.8.1)
- d. Air economizers (6.5.1)
- e. Heating equipment efficiency (6.8.1)
- f. Exhaust air energy recovery (6.5.6.1)
- g. Dual setpoint thermostat or manual changeover
- h. Heat pump auxiliary heat control
- i. No reheat or simultaneous cooling and heating for humidity control
- j. Off-hour shutoff and temperature setback/setup
- k. Piping insulation (*Tables 6.8.3A and 6.8.3B*)
- l. Ductwork insulation and sealing (6.4.4.2.1)
- m. Air balancing of ducted system
- n. Outdoor air intake and exhaust systems (6.4.3.4)
- o. Zone thermostatic controls to prevent simultaneous heating and cooling
- p. Optimum start controls
- q. Demand control ventilation (*6.4.3.8*)
- r. *Door switch requirements (6.4.3.10)*

Section 6 – 6.5.1 (6.3.2.d) Economizers

The system shall either have an economizer, or use the economizer Trade-off Option

- Limited to unitary systems
- Requires higher minimum cooling efficiency (EER)
- Trade-off EER by
 - System size
 - Climate zone



Section 6 – 6.4 HVAC Mandatory Provisions

- ✓ Minimum Equipment Efficiency *(Section 6.4.1)*
- ✓ Calculations *(Section 6.4.2)*
- ✓ Controls *(Section 6.4.3)*
- ✓ HVAC System Construction and Insulation
(Section 6.4.4)

Section 6 - Heating, Ventilating, and Air Conditioning

Mandatory Provisions (Section 6.4)-many new provisions are added-some new areas addressed are systems for:

- *Computer rooms*
- *Commercial refrigerators and freezers*
- *Commercial refrigeration*
- *Parking garages*
- *Sensible heating systems*
- *New equipment types*
- *Controls requirements*

Section 6 - Heating, Ventilating, and Air Conditioning

6.4.1.1 Minimum Equipment Efficiencies-Listed Equipment Standard Rating and Operating Systems-adds new Tables for:

- *Heat Transfer Equipment*
- *Electrically Operated Variable Refrigerant-Flow Air Conditioners*
- *Electrically Operated Variable Refrigerant-Flow Air to Air and Applied Heat Pumps*
- *Air Conditioners and Condensing Units Serving Computer Rooms*
- *Commercial Refrigerators and Freezers*
- *Commercial Refrigeration*

Section 6 - Heating, Ventilating, and Air Conditioning

6.4.1.2 Minimum Equipment Efficiencies Listed Equipment Non Standard Operating Conditions-

6.4.1.2.1 Water-Cooled Centrifugal Chilling Packages- requirements are modified

6.4.1.2.2 Positive Displacement (Air- and Water- Cooled) Chilling Packages-new section added

6.4.1.4 Verification of Equipment Efficiencies- adds requirements for plate type liquid to liquid heat exchangers

Section 6 – 6.4.1.1 Minimum Equipment Efficiency

HVAC Equipment Covered

- ✓ *Electrically operated unitary* air conditioners and condensing units
- ✓ *Electrically operated unitary and applied* heat pumps (air, water, and ground source)
- ✓ Water-chilling packages (chillers)
- ✓ *Electrically operated* packaged terminal air conditioners and heat pumps, *single-package vertical air conditioners, single-package heat pumps, room air conditioners, and room air conditioner heat pumps*
- ✓ *Warm-air furnaces, warm-air furnaces/AC units, warm-air* duct furnaces and unit heaters
- ✓ *Gas- or oil-fired* boilers
- ✓ *Performance requirements for* heat rejection equipment (cooling towers)
- ✓ Heat transfer equipment (heat exchangers)
- ✓ *Electrically operated* variable refrigerant flow (VRF) air conditioners
- ✓ *Electrically operated* VRF air-to-air and applied heat pumps
- ✓ Air conditioners *and condensing units* serving computer rooms
- ✓ *Commercial refrigerators and freezers*
- ✓ *Commercial refrigeration*

ASHRAE 90.1 (2013) Significant Changes – Section 6 (7 of 31)

Section 6 - Heating, Ventilating, and Air Conditioning

6.4.2 Load Calculations

*6.4.2.1 Load Calculations-
requires design loads for
sizing equipment to be in
accordance with
ANSI/ASHRAE ACCA
Standard 183*



Section 6 - Heating, Ventilating, and Air Conditioning

6.4.2.2 Pump Head-new section added

6.4.3.3.2 Setback controls-modifies the heating setback temperature to 10 degrees below occupied heating setback.

6.4.3.3.3 Optimum Start Controls – requirements are modified

Section 6 – 6.4.3.1 Controls – Zone Thermostatic & Dead Band

Required for each zone

- Perimeter can be treated differently

Dead band controls

- Thermostats must have at least a 5°F dead band

Exceptions

- Thermostats that require manual changeover between heating and cooling modes
- Special occupancy or applications where wide temperature ranges aren't acceptable (e.g., retirement homes) and approved by *AHJ*



Section 6 – 6.4.3.3 Controls – Off-Hour

Temperature Control off-hour requirements

- Automatic shutdown
- Setback controls
- Optimum start
- Zone isolation

Exceptions, HVAC systems

- with heating and cooling capacity < 15,000 Btu/h
- intended to operate continuously

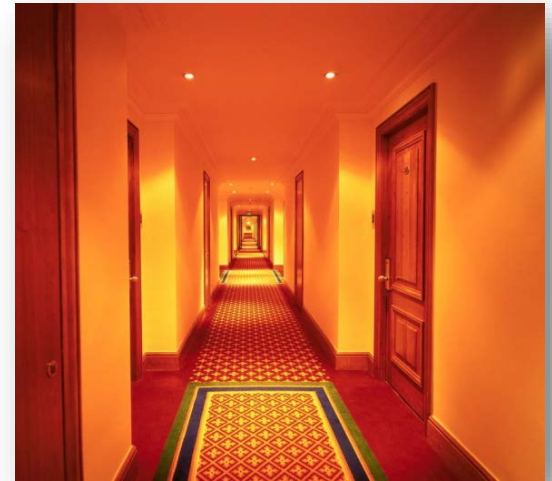

Section 6 – 6.4.3.3.1 Controls – Automatic Shutdown

Each HVAC system needs one of the following:

- Automatic time clock or programmable thermostat with 7-day/week schedule and 10-hour battery backup with two-hour manual override, **OR**
- Occupant sensor, **OR**
- Manually-operated timer with maximum two hour duration, **OR**
- Security system interlock

Exception

- Residential occupancies allowed to operate with only 2 different time schedules/wk

Section 6 – 6.4.3.3.2 Controls – Setback

Heating systems

- *Maintain unoccupied zone temperatures at an adjustable setpoint at least 10°F below occupied heating setpoint*

Cooling systems

- *Temporarily operate during unoccupied periods to*
 - *Maintain unoccupied zone temperatures at an adjustable setpoint at least 5°F above the occupied cooling setpoint*
 - *May operate cooling as needed to prevent high space humidity levels*

Exception

- *Radiant heating systems with setback heating setpoint at least 4°F below occupied heating setpoint*

Section 6 – 6.4.3.3.3 Controls – Optimum Start

Individual heating and cooling air distribution systems *with setback controls and DDC*

Control algorithm to be at least be a function of

- Difference between space temperature and occupied setpoint, *OA temp*, and amount of time prior to scheduled occupancy
- *Mass radiant floor slab systems to incorporate floor temperature into the optimum start algorithm*



Section 6 – 6.4.3.4 Controls – Ventilation System

Stair and Shaft Vent dampers (6.4.3.4.1)

- Motorized dampers automatically closed during normal building operation
- Interlocked to open as required by fire and smoke detection systems

Shutoff Damper Controls (6.4.3.4.2)

- All outdoor air intake and exhaust systems require motorized damper
- Ventilation outdoor air and exhaust/relief dampers capable of automatically shutting off during
 - Preoccupancy building warm-up, cool down, and setback
(Except when ventilation reduces energy costs or when ventilation must be supplied due to code requirements)

Exceptions

- Backdraft gravity dampers okay
 - For exhaust and relief in buildings < 3 stories in height **above grade**
 - Of any height in **climate zones 1 – 3**
 - Design intake or exhaust capacity of 300 cfm or less
- Ventilation systems serving unconditioned spaces
- Exhaust systems serving type 1 kitchen exhaust hoods

Section 6 – 6.4.3.4.3 Controls – Damper Leakage

Table 6.4.3.4.3 provides maximum leakage rates for outdoor air supply and exhaust dampers

Where OA supply and exhaust air dampers are required by Section 6.4.3.4

- They shall have a maximum leakage rate when tested in accordance with AMCA Standard 500 as indicated in Table 6.4.3.4.3



Section 6 – 6.4.3.4.4 Ventilation Fan Controls

Fans with motors > 0.75 hp shall have automatic controls complying with Section 6.4.3.3.1 that are capable of shutting off fans when not required

Exception

- HVAC systems intended to operate continuously

Section 6 – 6.4.3.4.5 Enclosed Parking Garage Ventilation

Ventilation systems in enclosed parking garages

- automatically detect contaminant levels and stage fans or
- modulate fan airflow rates to $\leq 50\%$, provided acceptable contaminant levels are maintained

Exception

- Garages $< 30,000 \text{ ft}^2$ with ventilation systems that do not use mechanical cooling or heating
- Garages with a garage area to ventilation system motor nameplate hp ratio $> 1500 \text{ ft}^2/\text{hp}$ and don't use mechanical cooling or heating
- Where permitted by AHJ

Section 6 – 6.4.3.5 Heat Pump Auxiliary Heat Control

Controls to prevent supplementary heat when heat pump can handle the load

Exception

- ✓ Heat pumps
 - With minimum efficiency regulated by NAECA, AND
 - With HSPF rating meeting Table 6.8.1-2 (*and the rating includes all usage of internal electric resistance heating*)



Section 6 – 6.4.3.6

Controls - Humidification and Dehumidification

General humidity control is limited:

- *Prevent use of fossil fuel or electricity to produce RH > 30% in warmest zone*
- *Reduce RH < 60% in coldest zone*
- Provide means to prevent simultaneous operation of humidification and dehumidification equipment
 - Limit switches, mechanical stops, or software programming (DDC systems)

Exceptions

- Zones served by desiccant systems, used with direct evaporative cooling in series
- Systems serving zones (museums and hospitals) where
 - specific humidity levels are required *by accreditation or approved by AHJ, and*
 - *configured to maintain a deadband of at least 10% RH with no active humidification or dehumidification*
- *Humidity levels are required by accreditation or approved by AHJ to be maintained with precision of not more than $\pm 5\%$ RH*

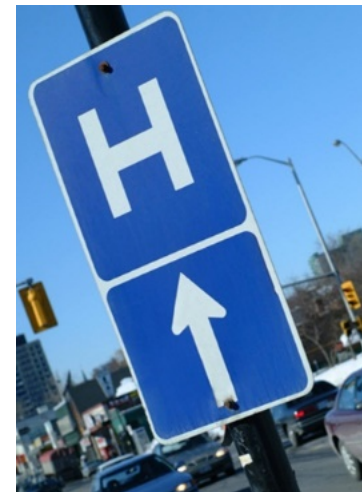
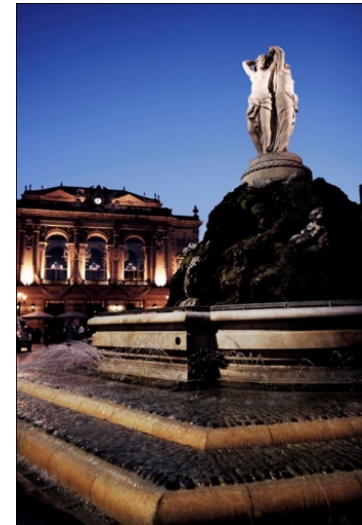

Section 6 – 6.4.3.7

Controls – Freeze Protection and Snow/Ice

Automatic controls to Shut off for

- ✓ Freeze protection systems
 - outside air temperatures $> 40^{\circ}\text{F}$ or when conditions of protected fluid will prevent freezing
- ✓ Snow- and ice-melting systems
 - pavement temperature $> 50^{\circ}\text{F}$ and no precipitation is falling and outdoor temperature $> 40^{\circ}\text{F}$

Section 6 – 6.4.3.9 Heating in Vestibules

Include automatic controls to

- *shut off heating system when OA temps are > 45°F*
- *Also controlled by a thermostat in the vestibule*
 - *Setpoint limited to max of 60°F*
- *Note: a single thermostat in vestibule limited to 45°F*
Would meet the requirements

Exception, vestibules:

- *with no heating system*
- *tempered with transfer air that would otherwise be exhausted*

Section 6 – 6.4.3.10 DDC Requirements

DDC provided in applications and qualifications in Table 6.4.3.10.1

Building Status	Application	Qualifications
New Building	Air-handling system and all zones served by the system	Individual system supplying more than three zones and with fan system bhp of 10 hp and larger
New Building	Chilled-water plant and all coils and terminal units served by the system	Individual plants supplying more than three zones and with design cooling capacity of 300,000 Btu/h and larger

Where required per the table, the DDC system must be capable to provide control logic per 6.5

- Monitoring zone and system demand for fan pressure, pump pressure, heating, and cooling*
- Transferring zone and system demand information from zones to air distribution system controllers and from air distribution systems to heating and cooling plant controllers*
- Automatically detecting those zones and systems that may be excessively driving the reset logic and generate an alarm or other indication to the system operator*
- Readily allowing operator removal of zone(s) from the reset algorithm*

Where required in new buildings, DDC system to be capable of trending and graphically displaying input and output points

Section 6 – 6.4.3.8 (6.3.2q) Demand Control Ventilation (1 of 2)

DCV must be provided for each zone with a area $> 500 \text{ ft}^2$ and the design occupancy > 25 people/1000 ft^2 where the HVAC system has:

- ✓ air-side economizer,
- ✓ automatic modulating control of OSA dampers
- ✓ design outdoor airflow $> 3,000 \text{ cfm}$

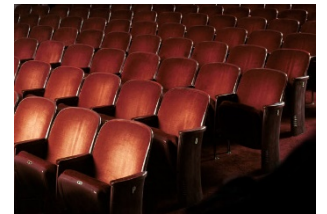

Demand control ventilation (DCV): a ventilation system capability that provides for the automatic reduction of outdoor air intake below design rates when the actual occupancy of spaces served by the system is less than design occupancy.

Section 6 – 6.4.3.8 (6.3.2q) Demand Control Ventilation (2 of 2)

Exceptions:

- Systems with exhaust air energy recovery meeting 6.5.6.1
- Multiple-zone systems without DDC of individual zones communicating with central control panel
- Systems with design outdoor air flow < 750 cfm
- *Spaces where > 75% of space design outdoor airflow is required for makeup air exhausted from space or transfer air exhausted from other spaces*
- *Spaces with one of the following occupancy categories per ASHRAE 62.1*
 - *Correctional cells*
 - *Daycare sickrooms*
 - *Science labs*
 - *Barbers, beauty, and nail salons*
 - *Bowling alley seating*

Section 6 - Heating, Ventilating, and Air Conditioning

6.4.3.4.2 Shutoff Damper Controls- -Exceptions are changed as to when motorized dampers are required-motorized dampers not required for unconditioned spaces

6.4.3.4.3 Damper Leakage-requires outdoor air supply and exhaust dampers allowable leakage rates to comply with Table 6.4.3.4.3 and to meet AMC Standard 500.

Section 6 - Heating, Ventilating, and Air Conditioning

6.4.3.4.5 Enclosed Parking Garage Ventilation-adds new section on parking garage ventilation and defines requirement to detect contaminant levels, modulate air flow rates and provides several exceptions.

Section 6 - Heating, Ventilating, and Air Conditioning

*6.4.3.6 Humidification and Dehumidification-
language added which limits the use of fossil fuels
for humidification and dehumidification for certain
RH limits.*

Section 6 - Heating, Ventilating, and Air Conditioning

6.4.3.8 Ventilation Controls for High Occupancy Spaces-modifies the occupancy level per 1000 sf for when demand control ventilation is required-the exceptions are also modified.

Section 6 - Heating, Ventilating, and Air Conditioning

6.4.3.9 Heating in Vestibules-new section requires automatic controls to shut off heating system when outdoor temperature is above 45°F.

Section 6 - Heating, Ventilating, and Air Conditioning

Direct Digital Control (DDC) Requirements-New section added which requires DDC for applications identified in Table 6.4.3.10.1-this section provides an exception for systems using the simplified approach.

Section 6 – 6.4.4.1.2 Duct and Plenum Insulation (1 of 2)

All supply and return ducts and plenums to be insulated per Tables 6.8.2-1 and 6.8.2-2

Exceptions

- Factory-installed plenums, casings, or ductwork furnished as part of HVAC equipment
- Ducts located in heated, semiheated, or cooled spaces
- For runouts < 10 ft in length to air terminals or air outlets, the R-value need not exceed R-3.5
- Backs of air outlets and outlet plenums exposed to unconditioned or indirectly conditioned spaces with face areas > 5 ft² need not exceed R-2; those ≤ 5 ft² need not be insulated

Section 6 – 6.4.4.1.2 Duct and Plenum Insulation (2 of 2)

All supply and return ducts and plenums to be insulated per Tables
6.8.2-1 and *6.8.2-2*

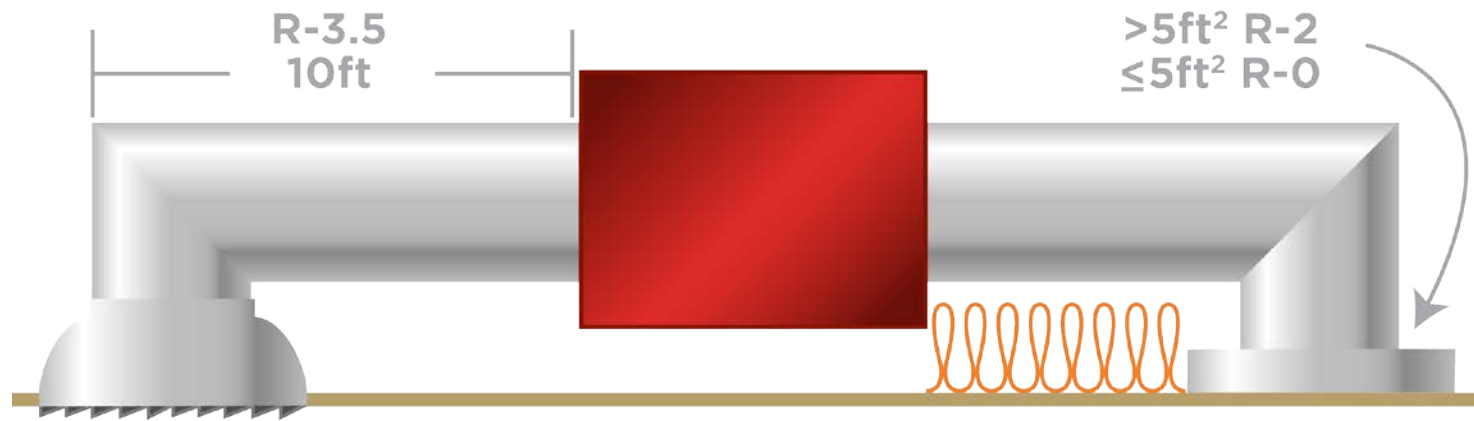

Section 6 – 6.4.4.2.2 Duct Leakage Tests

Designed > 3 in. w.c.

- Leak tested
- Representative sections $\geq 25\%$ of the total installed duct area shall be tested
- Ratings > 3 in. w.c. to be identified on drawings
- Maximum permitted duct leakage
 - $L_{max} = C_L P^{0.65}$
 - Where L_{max} = maximum permitted leakage in cfm/100 ft² duct surface area



Section 6 - Heating, Ventilating, and Air Conditioning

6.4.4.1.3 Piping Insulation- this section refers to Tables 6.8.3-1 and 6.8.3-2 for piping insulation requirements. Most insulation thicknesses are changed in these table.

Section 6 - Heating, Ventilating, and Air Conditioning

6.4.4.1.4 Sensible Heating Panel Insulation-new section requiring ineffective portions to be insulated to minimum dehumidification to certain relative humidity ranges R3.5

6.4.4.1.5 Radiant Floor Heating-new section added requiring minimum R3.5 on the bottom surface.

Section 6 - Heating, Ventilating, and Air Conditioning

6.4.4.2 Duct Sealing-modifies duct sealing requirements

Section 6 - Heating, Ventilating, and Air Conditioning

*6.4.5 Walk-in Coolers and Freezers-new section added
addressing requirements for Walk-in Coolers and Freezers*

*6.4.6 Refrigerated Display Case-new section added
addressing requirements for refrigerated display cases*

Section 6 - Heating, Ventilating, and Air Conditioning

Prescriptive Building Envelope Option (Section 6.5)-many changes

6.5.1 Economizers-a number of changes are made to the exceptions for when economizers are required-new or modified exception language addresses hospitals and ambulatory surgery centers and computers rooms

6.5.1.1.6 Sensor Accuracy-a new section is added addressing sensor accuracy for Air Economizers

Section 6 - Heating, Ventilating, and Air Conditioning

Prescriptive Building Envelope Option (Section 6.5)-many changes
6.5.1.2 Water Economizers-outdoor air temperatures are modified for when the system must be capable of supplying 100% of the cooling. Exceptions are added for certain computer room conditions.

6.5.1.3 Integrated Economizer Control- requirements are modified and added addressing the controls for economizers

6.6.1.6 Economizer Humidification System Impact-new section added requiring an economizer to be water cooled if one is required to maintain certain RH levels

Section 6 - Heating, Ventilating, and Air Conditioning

- *6.5.2 Simultaneous Heating*
- *6.5.2.1 Zone Controls-some of the exceptions for when zone controls are required in preventing reheating, re-cooling, mixing or simultaneous heating and cooling are modified.*
- *6.5.2.1.1 Supply Air Temperature Reheat Limit-new section added*
- *6.5.2.4 Humidification-requirements are modified*
- *6.5.2.5 Preheat Coils-new section is added*

Section 6 - Heating, Ventilating, and Air Conditioning

- *6.5.3.2 Fan Control-subsections modified or added –including:*
 - *6.5.3.2.1 Fan Controls*
 - *6.5.3.2.2 VAV Static Pressure Sensor Locations*
 - *6.5.3.2.3 VAV Set Point Reset*
- *6.5.3.3 Multiple-Zone VAV Systems Ventilation Optimization Control*
- *6.5.3.4 Supply Air Temperature Reset Controls*
- *6.5.3.5 Fractional Horsepower Fan Motors*

Section 6 - Heating, Ventilating, and Air Conditioning

- *6.5.4 Hydronic Systems- subsections modified or added-*
- *6.5.4.1 Boiler Turndown*
- *6.5.4.2 Hydronic Variable Flow Systems*
- *6.5.4.3 Chiller and Boiler Isolation*
- *6.5.4 Hydronic (Water Loop) Heat Pumps and Water-Cooled Unitary Air-Conditioners*
- *6.5.4.6 Pipe Sizing*

Section 6 - Heating, Ventilating, and Air Conditioning

- *6.5.5 Heat Rejection Equipment – new sections added-*
- *6.5.5.2.2 addresses Multi-cell heat rejection equipment,*
- *6.5.5.3 Limitations on Centrifugal Fan Open Circuit Cooling Towers*
- *6.5.5.4 Tower Fan Turndown*

Section 6 - Heating, Ventilating, and Air Conditioning

*6.5.6 Heat Recovery-6.5.6.1 - is modified and refers to
Tables 6.5.6.1-1 and 6.5.6.1-2 to determine when heat
recovery is required.*

Section 6 - Heating, Ventilating, and Air Conditioning

- *6.5.7 Exhaust Systems*
- *6.5.7.1 Kitchen Exhaust Systems-all subsections including*
- *6.5.7.1.5 Performance Testing are modified*
- *6.5.7.2 Laboratory Exhaust Systems- requirements are modified*

Section 6 - Heating, Ventilating, and Air Conditioning

6.5.10 Door Switches-new section added requires doors opening to the outside be provided with a control that disables or resets heating and cooling within 5 minutes of the door opening.

Exceptions for entries with automatic closing devices, spaces without thermostats, alterations to existing buildings and loading docks.

Section 6 - Heating, Ventilating, and Air Conditioning

- *6.5.11 Condensers Serving Refrigeration Systems-new section added*
- *6.5.11.2 Compressor Systems-new section added*

Section 6 - Heating, Ventilating, and Air Conditioning

Alternative Compliance Path (Section 6.6)

- *6.6.1 Computer Room Systems-new section added which addresses an alternative approach for HVAC systems for computer rooms*

Section 6 - Heating, Ventilating, and Air Conditioning

6.7.2.4 System Commissioning-this section requires controls to be tested to ensure systems are calibrated and working properly. ASHRAE 90.1 (2013) requires detailed commissioning instructions be provided by the designers in the plans and specifications when conditioned floor area exceeds 50,000 sf.

**Michigan has amended this requirement to be triggered at 10,000 sf. Except for warehouses and semi-heated spaces*

Section 6 - Heating, Ventilating, and Air Conditioning

Minimum Equipment Efficiency Tables (Section 6.8)

- *6.8.1 Minimum Efficiency Requirement Listed Equipment-Standard Rating-Operating Conditions-many values are modified*
- 6.8.2 Duct Insulation-generally the same as before
- *6.8.3 Pipe Insulation-most values are modified*

Section 6 – 6.4.4 HVAC System Construction and Insulation

- ✓ Insulation installed in accordance with industry-accepted standards
- ✓ Insulation protection
- ✓ Duct and plenum insulation
- ✓ Piping insulation
- ✓ Sensible heating panel insulation
- ✓ Radiant floor heating
- ✓ Duct sealing
- ✓ Duct leakage tests



Section 6 – 6.4.5 Walk-in Coolers and Freezers

Site assembled or site constructed walk-ins ≤ 3000 sq ft

- *Automatic door closers that close doors within 1 inch of full closure for doors ≤ 3 ft 9 in. wide or ≤ 7 ft tall*
- *Strip doors (curtains), spring-hinged doors, or other way to minimize infiltration when doors are open*
- *Wall, ceiling and door insulation*
 - *Walk-in coolers ≥ R-25*
 - *Walk-in freezers ≥ R-32*

Exception: glazed portions of doors or structural members
- *Floor insulation*
 - *Walk-in freezers ≥ R-28*

Section 6 – 6.4.5 Walk-in Coolers and Freezers

- *Use electronically commutated motors or three-phase motors for evaporator fan motors < 1 hp and < 460 V*
- *Use light sources with efficacy ≥ 40 lm/W (including any ballast losses)*
 - *May use light sources with efficacy < 40 lm/W in conjunction with a timer or device to turn off the lights within 15 minutes of last occupation*
- *transparent reach-in doors and windows in walk-in doors either filled with inert gas or heat-reflective treated glass*
 - *freezers: triple-pane glass*
 - *coolers: double-pane glass*
- *for Antisweat heaters without antisweat heater controls to have a total door rail, glass, and frame heater power draw*
 - *≤ 7.1 W/ft² of door opening for walk-in freezers*
 - *≤ 3.0 W/ft² of door opening for walk-in coolers*
- *Antisweat heater controls to reduce the energy use of the antisweat heater as a function of the RH in the air outside the door or condensation on the inner glass plane*
- *Use electronically commutated motors, permanent split capacitor-type motors, or three-phase motors for condenser fan motors < 1 hp*
- *Walk-in freezers to incorporate primary temperature-based defrost termination control with a secondary time limit*

Section 6 – 6.4.6 Refrigerated Display Case

- *Meet equipment efficiency requirements*
- *Lighting to be controlled by one of these:*
 - *automatic time-switch to turn off lights during non-business hours with timed overrides to turn lights on for ≤ 1 hr*
 - *Motion sensors that reduce lighting power by $\geq 50\%$ within 3 minutes after sensor area is vacated*
- *Low-temperature cases to have primary temperature-based defrost termination control with secondary time-limit termination.*
- *Antisweat heater controls to reduce energy use of antisweat heater as function of RH in air outside the door or to condensation on inner class pane*

Section 6 – 6.5 HVAC Prescriptive Path

- ✓ Economizers (Section 6.5.1)
- ✓ Simultaneous Heating and Cooling Limitation (Section 6.5.2)
- ✓ Air System Design and Control (Section 6.5.3)
- ✓ Hydronic System Design and Control (Section 6.5.4)
- ✓ Heat Rejection Equipment (Section 6.5.5)
- ✓ Energy Recovery (Section 6.5.6)
- ✓ Exhaust Systems (Section 6.5.7)
- ✓ Radiant Heating Systems (Section 6.5.8)
- ✓ Hot Gas Bypass Limitation (Section 6.5.9)
- ✓ **Door Switches** (Section 6.5.10)
- ✓ **Refrigeration Systems** (Section 6.5.11)

Section 6 – 6.5.1.1.5 Relief of Excess Outdoor Air

Means to relieve excess outdoor air during economizer operation to prevent overpressurizing the building

Outlet located to avoid recirculation into the building

Section 6 – 6.5.1.2.1

Design Capacity – Water Economizers

System capable of cooling supply air by indirect evaporation and providing up to 100% of expected system cooling load at outside air temperatures of 50°F dry bulb/45°F wet bulb and below

Exceptions

- Systems primarily serving computer rooms
 - Where 100% of expected system cooling load at dry bulb and wet bulb *in Table 6.5.1.2.1* is met with evaporative water economizers
 - With *systems* that satisfy 100% of expected system cooling load at the dry bulb *in Table 6.5.1.2.1 is met with dry cooler water economizers*
- If required for dehumidification, design can meet 100% of expected cooling load at 45°F dry bulb/40°F wet bulb with evaporative water economizers

Section 6 – 6.5.1.2.2 Maximum Pressure Drop – Water Economizers

Precooling coils and water-to-water heat exchangers to have either

- Water-side pressure drop of <15 ft of water
- OR**
- Bypassed when not in use

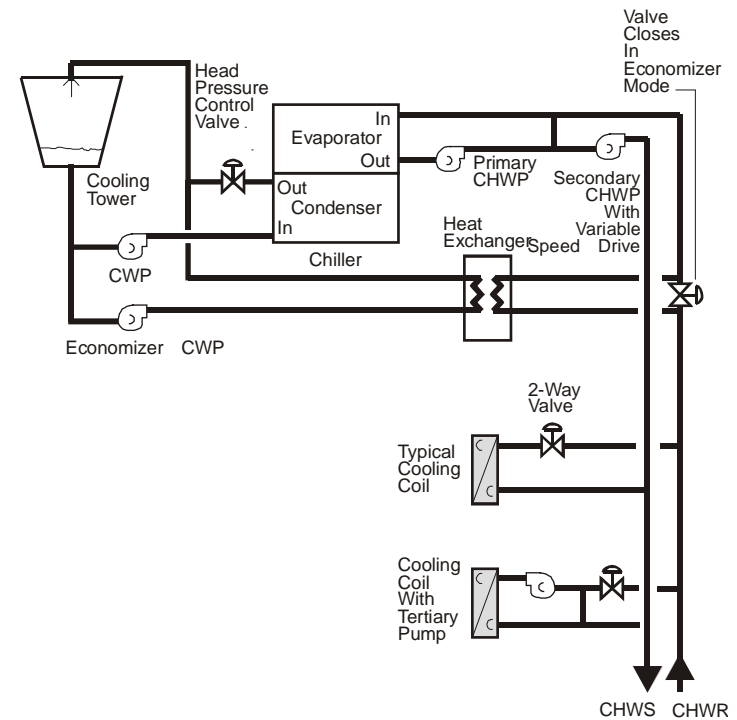

Figure 6-0 from
90.1 User's Manual

Section 6 – 6.5.1.3 Integrated Economizer Control (1 of 2)

Economizers must be integrated with mechanical cooling systems and be capable of providing partial cooling even when additional mechanical cooling is required

Controls to not false load the mechanical cooling systems by limiting or disabling the economizer or any other means (e.g., hot gas bypass) except at lowest cooling stage

Section 6 – 6.5.1.3 Integrated Economizer Control (2 of 2)

Units with air economizers

- *Unit controls*
 - *Mechanical cooling capability interlocked with air economizer controls so outdoor air damper is at 100% open when mechanical cooling is on and outdoor air damper doesn't begin to close to prevent coil freezing due to minimum compressor run time until leaving air temperature is $< 45^{\circ}\text{F}$*
- *DX units that control capacity of mechanical cooling based on occupied space temperature to have a minimum of 2 stages of mechanical cooling capacity if unit cooling capacity is $\geq 75,000 \text{ Btu/h}$ ($\geq 65,000 \text{ Btu/h}$ effective 1/1/16)*

Section 6 – 6.5.1.5 Economizer Heating System Impact

Designed so economizer operation doesn't increase the building heating energy use during normal operation

Exception

- ✓ Economizers on VAV systems that cause zone level heating to increase due to a reduction in supply air temperature



Section 6 – 6.5.1.6 Economizer Humidification System Impact

Systems with hydronic cooling and dehumidification systems designed to maintain inside humidity at a dewpoint > 35°F to use a water economizer (if 6.5.1 requires an economizer)

Section 6 – 6.5.2.1 Zone Thermostatic Controls

Capable of operating in sequence the supply of heating and cooling energy to the zone

Controls prevent

- Reheating
- Recooling
- Mixing or simultaneously supplying air previously heated or cooled
- Other simultaneous operation of heating and cooling systems to the same zone

Section 6 – 6.5.2.2.1 Three-Pipe System

No common return system for both hot

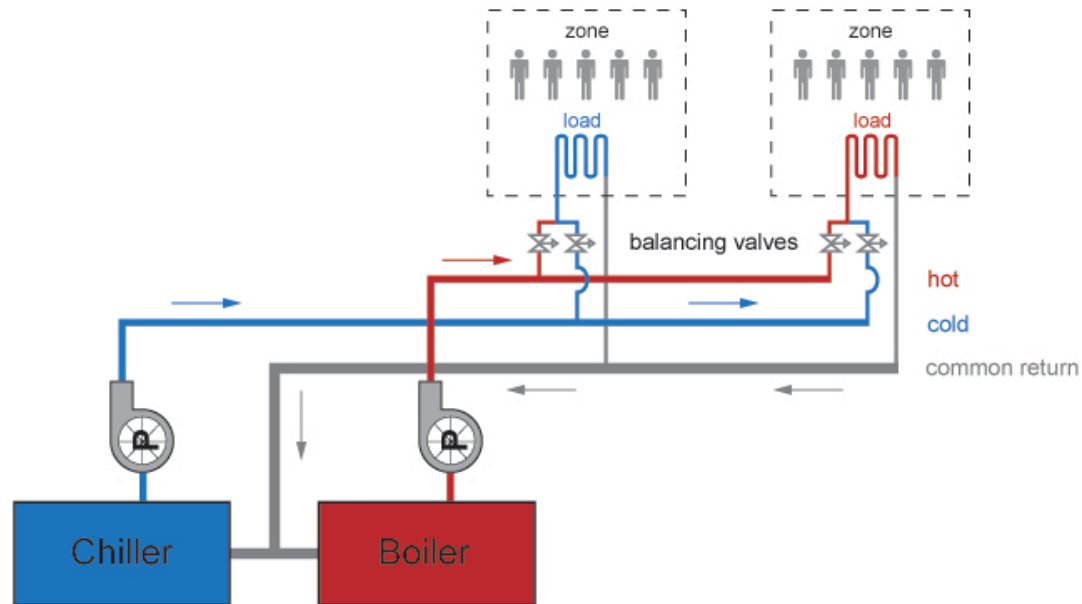

Section 6 – 6.5.2.2.2 Two-Pipe Changeover System

Two-pipe changeover system is allowed if it meets the following requirements:

- Dead band from one mode to another is $\geq 15^{\circ}\text{F}$ outdoor air temperature
- Controls to allow operation of ≥ 4 hours in one mode before changing to another mode
- Reset controls so heating and cooling supply temperatures at changeover point no more than 30°F apart

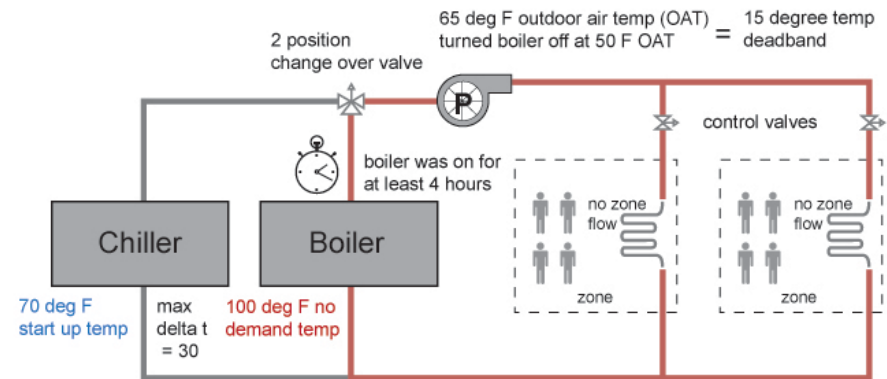

Diagram Courtesy of Ken Baker

Section 6 – 6.5.2.3 Dehumidification

Humidistatic controls to prevent

- Reheating
- Mixing of hot and cold air streams
- Heating and cooling of same air stream

Section 6 – 6.5.2.3 Dehumidification Exceptions

- Systems reduces supply air flow to 50%, or to minimum ventilation
- Systems $\leq 65,000$ Btu/h that can unload at least 50%
- Systems smaller than 40,000 Btu/h
- Process applications *where building includes site-recovered or site solar energy source that provides energy equal to $\geq 75\%$ of annual energy for reheating or providing war air in mixing systems* (exception does NOT apply to computer rooms)
- *90%* of reheat or re-cool *annual* energy is recovered or solar
- Systems where heat added to airstream is result of use of desiccant system and 75% of heat added by desiccant system is removed by a heat exchanger (either before or after desiccant system with energy recovery)

Section 6 – 6.5.8 Radiant Heating Systems

Required for unenclosed spaces
exception: loading docks with air curtains

Radiant heating systems that are used as primary or supplemental enclosed space heating must be in conformance with the governing provisions of the standard

- Radiant hydronic ceiling or floor panels
- Combination or hybrid systems with radiant heating (or cooling) panels
- Radiant heating (or cooling) panels used in conjunction with other systems such as VAV or thermal storage systems

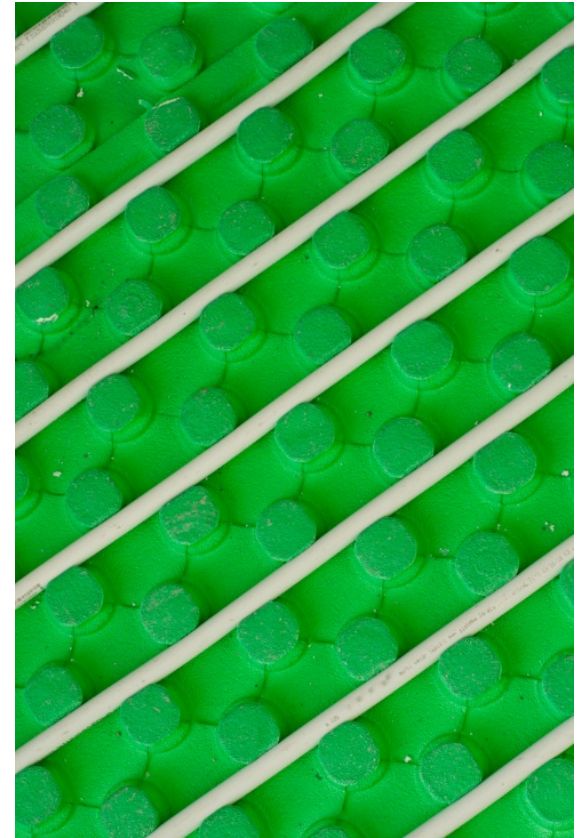

Section 6 – 6.5.10 Door Switches

Doors that open to the outdoors from a conditioned space must have controls to do the following when the doors are open:

- *Disable mechanical heating or reset heating setpoint to $\leq 55^{\circ}\text{F}$ within 5 minutes of door opening*
- *Disable mechanical cooling or reset cooling setpoint to $\geq 90^{\circ}\text{F}$ within 5 minutes of door opening*
 - *Mechanical cooling can remain if outdoor air temperature is $<$ space temperature*

Exceptions

- *Building entries with automatic closing devices*
- *Spaces without thermostats*
- *Alterations to existing buildings*
- *Loading docks*

Section 6 – 6.5.11.2 Compressor Systems

- *Compressors and multiple-compressor systems suction groups*
 - *Include control systems using floating suction pressure control logic to reset target suction pressure temperature based on temperature requirements of attached refrigeration evaporators*

Exceptions

- *Single-compressor systems without variable capacity capability*
- *Systems serving suction groups*
 - *With design saturated suction temperature $\geq 30^{\circ}\text{F}$*
 - *Comprise the high stage of a two-stage or cascade system, or*
 - *Primarily serve chillers for secondary cooling fluids*

Section 6 – 6.6.1 Alternative Compliance Path

Computer Rooms Systems

HVAC systems serving the heating, cooling, or ventilating needs of a computer room shall comply with Sections 6.1, 6.4, 6.6.1.1 or 6.6.1.2, 6.6.1.3, 6.7, and 6.8. 6.6.1.1 or 6.6.1.2 cover two approaches to Power Usage Effectiveness (PUE).

- **Annual Energy:** $PUE_1 \leq$ the values listed in Table 6.6.1. Hourly simulation for calculating PUE_1 , based on Appendix G simulation methodology.

Exceptions: This compliance path is not allowed for a proposed computer room design utilizing a combined heat and power system.

- **Peak Power:** $PUE_0 \leq$ the values listed in Table 6.6.1. Limited to systems only utilizing electricity. $PUE_0 =$ the highest value determined at outdoor cooling design temperatures, calculated for two conditions: 100% design IT equipment energy and 50% design IT equipment energy.
- **Documentation required:** energy consumption or demand of IT equipment, power distribution losses, HVAC systems, and lighting.

Section 6 – 6.7 Submittals

- ✓ Record drawings
- ✓ Operating and maintenance manuals
- ✓ System balancing
- ✓ System commissioning

Section 6 - 6.7.2.3 System Balancing

- Systems shall be balanced in accordance with accepted engineering standards
- Written report for conditioned spaces > 5000 ft²
- Minimize throttling losses
- For fans with system power > 1 hp
 - Adjust fan speed to meet design flow conditions

Performance Paths in Standard 90.1

- Standard 90.1 includes 2 performance paths
 - Both based on energy simulation
 - Both compare a proposed building design to a baseline building meeting the prescriptive requirements of the code
 - Both compare the annual energy cost (\$) of the proposed building to the baseline building

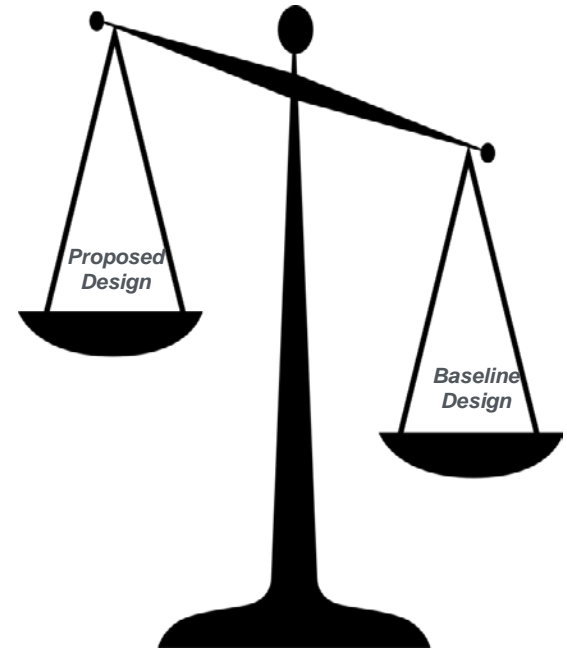

COMcheck Online Tool



COMcheck-Web simplifies commercial and high-rise residential energy code compliance.

It performs just like [COMcheck](#), the desktop version, but you don't need to download or install any software on your computer.

» [Start COMcheck-Web](#)



COMcheck-Web has been updated!
[Learn what's new.](#) (January 2011)

Contact: [Technical Support](#)
[Security & Privacy](#)

Link to COMcheck web-based software

<https://energycode.pnl.gov/COMcheckWeb/>

Energy Cost Budget Method (Section 11)

- The ultimate trade-off method allowing you to trade-off across building systems through the use of annual, hourly simulation tools and a baseline building
- The only real way to deal with unique designs, renewables, high-efficiency equipment, etc.
- The basis of the energy portion of the LEED rating
- Limits allowable energy costs of the design to those of a building meeting the Standard
- Buildings must still meet all mandatory requirements (Section X.4)



U.S. Department of Energy (2010)

Energy Cost Budget Method (1 of 4)

- Tradeoff limited to building permit (*Section 11.1.2*)
- You have to have an approved building envelope design prior to ECB submittal (*Section 11.1.3*)
- You must meet all the X.4 sections AND the design energy cost cannot exceed the energy cost budget AND the energy efficiency level of components must meet or exceed the levels used to calculate the design energy cost (*Section 11.1.4*)
- You must document all this in great detail (*Section 11.1.5*)

Energy Cost Budget Method (2 of 4)

- Use a good and approved simulation program (*Section 11.2.1*)
- Use appropriate and approved climate data (*Section 11.2.2*)
- Use appropriate and approved purchased energy rates (*Section 11.2.3*)
- Use the same simulation program, climate data, and purchased energy rates for both the design energy cost and energy cost budget (*Section 11.2.4*)
- Get approval to deal with exceptional calculations that aren't covered in the simulation program (*Section 11.2.5*)

Energy Cost Budget Method (3 of 4)

- Develop your proposed building design and budget building design in accordance with Table 11.3.1 (*Section 11.3.1*)
 - This table “locks down” a number of building design parameters
- Choose your budget building HVAC system from Figure 11.3.2 and Table 11.3.2A (*Section 11.3.2*)

Energy Cost Budget Method (4 of 4)

If you are attempting to show that your building goes “above code” (say, for instance, for LEED energy points) as opposed to simply using ECB as a very flexible and complex code compliance tradeoff option

- Be sure to see Informative Appendix G, which contains many of the same elements as Section 11, but with modifications to accommodate the needs of “above code” programs

Performance Paths in Standard ASHRAE 90.1

- Energy Cost Budget Method (ECB) - Chapter 11
 - Used for minimum code compliance for buildings that do not meet 90.1 prescriptive requirements
 - Requires no greater energy cost than a building that meets those prescriptive requirements
- Performance Rating Method - Appendix G
 - Used to rate building performance “beyond code”. LEED, EPACT tax credits, utility programs, ASHRAE Standard 189.1, IgCC
 - % improvement = $100 \times (\text{baseline} - \text{proposed}) / \text{baseline}$

Performance Updates in 90.1-2013

- Total of 20 addenda incorporated into 90.1-2013 that impact one or both of the performance paths
- 15 impact the Performance Rating Method only
- 5 impact both the Performance Rating Method and the Energy Cost Budget method.

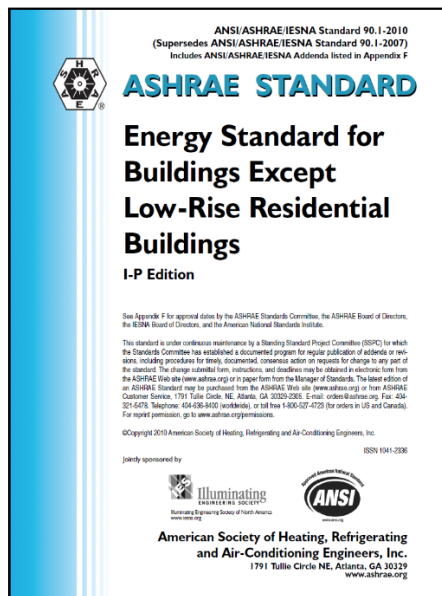

+ *addenda* =

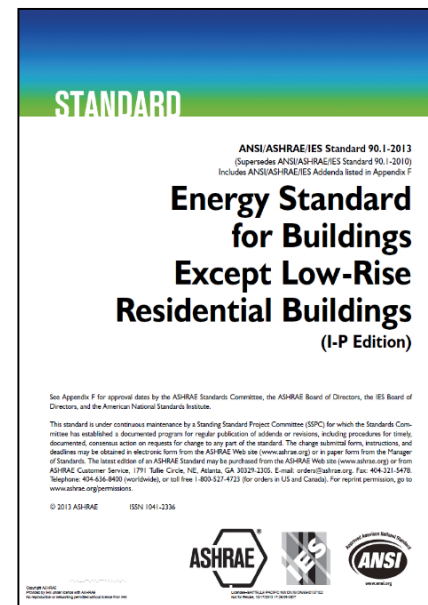

LEED and Energy Codes (1 of 5)

LEED v4

Voluntary Standards
Based Systems

Documented
Achievement based
Approach



LEED and Energy Codes (2 of 5)

LEED and Energy Codes

- LEED V4 References IECC 2012
- Requires whole building energy simulation in accordance with the ASHRAE 90.1 Appendix G

LEED and Energy Codes (3 of 5)

Energy and Atmosphere Credits

●	Fundamental commissioning and verification Required
●	Minimum energy performance Required
●	Building-level energy metering Required
●	Fundamental refrigerant management Required
●	Enhanced commissioning Up to 8 points
●	Optimize energy performance Up to 18 points
●	Advanced energy metering 1 point
●	Demand response Up to 2 points
●	Renewable energy production Up to 2 points
●	Enhanced refrigerant management 1 point
●	Green power and carbon offsets Up to 2 points

LEED and Energy Codes (4 of 5)

Minimum Energy Performance



LEED BD+C: New Construction | v4 - LEED v4

Minimum energy performance

Required

Language Guide Resources All credits Previous Next

Glossary

Intent

To reduce the environmental and economic harms of excessive energy use by achieving a minimum level of energy efficiency for the building and its systems.

Requirements

Option 1. Whole-building energy simulation

Demonstrate an improvement of 5% for new construction, 3% for major renovations, or 2% for core and shell projects in the proposed building performance rating compared with the baseline building performance rating. Calculate the baseline building performance according to ANSI/ASHRAE/IESNA Standard 90.1 –2010, Appendix G, with errata ([or a USGBC-approved equivalent standard for projects outside the U.S.](#)), using a simulation model.

Projects must meet the minimum percentage savings before taking credit for renewable energy systems.

Join LEEDuser

Ask questions, share tips, and get notified of new forum posts by joining LEEDuser, a tool developed by BuildingGreen and supported by USGBC!

[CREATE FREE ACCOUNT](#)

Share on Twitter
Share on Facebook
Share on LinkedIn
Print to PDF

Sample forms

Version: v01
[Active Form](#)

ASHRAE 90.1 2010

LEED and Energy Codes (5 of 5)

Optimize Energy Performance



LEED BD-C: New Construction | v4 - LEED v4

Optimize energy performance

Possible 18 points

Language Guide Resources All credits Previous Next

Glossary

Intent

To achieve increasing levels of energy performance beyond the prerequisite standard to reduce environmental and economic harms associated with excessive energy use.

Requirements

Establish an energy performance target no later than the schematic design phase. The target must be established as kBtu per square foot-year (kW per square meter-year) of source energy use.

Choose one of the options below.

Option 1. Whole-building energy simulation (1–18 points except Schools and Healthcare, 1–16 points Schools, 1–20 points Healthcare)

Analyze efficiency measures during the design process and account for the results in design decision making. Use energy simulation of efficiency opportunities, past energy simulation analyses for similar buildings, or published data (e.g., Advanced Energy Design Guides) from analyses for similar buildings.

Analyze efficiency measures, focusing on load reduction and HVAC-related strategies (passive measures are acceptable) appropriate for the facility. Project potential energy savings and holistic project cost implications related to all affected systems.

Join LEEDuser

Ask questions, share tips, and get notified of new forum posts by joining LEEDuser, a tool developed by BuildingGreen and supported by USGBC!

[CREATE FREE ACCOUNT](#)

[Share on Twitter](#)

[Share on Facebook](#)

[Share on LinkedIn](#)

[Print to PDF](#)

Sample forms

No sample form available for this credit.

[VIEW ALL SAMPLE FORMS](#)

Energy Codes-Resources

U.S. DEPARTMENT OF ENERGY | Energy Efficiency & Renewable Energy

EERE Home | Programs & Offices | Consumer Information

Building Energy Codes Program

Building Energy Codes

HOME NEWS EVENTS ABOUT

U.S. Department of Energy » Energy Efficiency and Renewable Energy » Building Technologies Office » BECP Home

Site Map | Printable Version | SHARE

DEVELOPMENT
ADOPTION
COMPLIANCE
RESOURCE CENTER



Do Code Controls Requirements Save Energy in Real Buildings?
The next webinar in the *Energy Code Commentator Training Series*, scheduled for April 13, 2017 at 1 p.m. (EDT), will examine the findings of a study that reviewed energy savings resulting from the implementation of code controls requirements in real buildings. [Learn more...](#)

Popular Links

Tools

- COMcheck
- REScheck

Technical Assistance

- Help Desk

Status of State Energy Codes

Select a state

News

- [A Perspective of Energy Codes and Regulations for the Buildings of the Future](#)
Source: ASME, posted: 02.2017
- [What architects should know about building modeling in](#)

www.energycodes.gov



Q + A

MICHIGAN STATE
UNIVERSITY